



BONDED ABRASIVES

ENGINEERING
SURFACES

PRODUCT
CATALOGUE



CARBORUNDUM UNIVERSAL LIMITED

ABOUT US

Carborundum Universal Limited (CUMI) is part of the US\$ 4.4 billion conglomerate Murugappa Group. The company pioneered the manufacture of Coated Abrasives and Bonded Abrasives in India. In addition, we also manufacture Super Abrasives, Super Refractories, Electro Minerals, Industrial Ceramics, Ceramic Fiber and Power Tools.

CUMI manufactures the complete range of Vitrified, Resinoid and Rubber Bonded Products for various industrial applications; Cylindrical Grinding, Centerless Grinding, Surface Grinding, Face Grinding and complete range of Coated Products: Abrasive Paper, Fibre Discs, Rolls, Flap Discs, Non-Woven and Flap Wheels.

Our products address various type of industries: Automobile OEM, Auto Components, Steel, Bearing, Foundry, General Engineering, Aerospace and Wood. We also have unique products for Ball Grinding, Ball Lapping, Roll Grinding etc.

CUMI's strong R&D and Application support team provide complete grinding system engineering and technical support to customers. With strategic global alliances, state of the art manufacturing facilities and sales support centres that span across North America, Europe, Russia, South Africa, India, China and Australia, CUMI has achieved a reputation for quality and innovation.

CUMI specializes and develops specific products to meet the requirements of customers and markets.

CUMI



BONDED
ABRASIVES



COATED
ABRASIVES



NON WOVEN
ABRASIVES



CUTTING AND
GRINDING WHEELS









DIAMOND
TOOLS

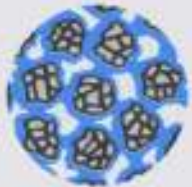

POWER
TOOLS



INDEX

S.NO.	MODULE		PG. NO.
1	INTRODUCTION		6
2	CENTERLESS GRINDING WHEELS		15
3	CYLINDRICAL GRINDING WHEELS		27
4	CRANKSHAFT GRINDING WHEELS		33
5	CAMSHAFT GRINDING WHEELS		37
6	F TYPE GRINDING WHEELS (DOUBLE DISC)		42

INDEX

S.NO.	MODULE		PG. NO.
7	BORE GRINDING WHEELS		49
8	IR TRACK GRINDING WHEELS		53
9	THREAD GRINDING WHEELS		58
10	FLUTE GRINDING WHEELS		62
11	BALL GRINDING & LAPPING WHEELS		66
12	CREEP-FEED GRINDING WHEELS		72

INDEX

S.NO.	MODULE		PG. NO.
13	GEAR GRINDING WHEELS		76
14	ROLL GRINDING WHEELS		85
15	SNAGGING WHEELS		89
16	CUP WHEEL GRINDING		93
17	TOOL ROOM GRINDING WHEELS		97

BONDED ABRASIVES

About Bonded Abrasives

Bonded abrasives is a terminology collectively used for a range of abrasive products where abrasive grains are held together by bonding materials moulded into various shapes like grinding wheels, segments, dressing sticks, mounted points etc.,

Grinding wheel is a multi point cutting tool composed of abrasive grains held together by bonding material (bond) and separated by voids. The abrasive grains provide the cutting points, which in turn helps in cutting the material to the required dimensional accuracy or help impart a fine surface finish. The arrangement of the abrasive grains and the bond in the grinding wheels gives a specific volume of pores known as 'structure'. These pores are designed based on application needs and provide chip clearance.

The major types of grinding are

a) Precision grinding b) Non-Precision grinding or Offhand grinding

With latest developments in technology, we at CUMI pride ourselves in being one of the top manufacturers in the world for both precision and non-precision grinding applications. Our range of grinding wheels are used for various grinding applications that include Ball Grinding & Lapping, Crankshaft & Camshaft grinding, Gear grinding, Centerless grinding, Cylindrical grinding, Creep feed grinding, Thread grinding, Flute grinding, Roll grinding, Bore grinding, Track grinding, Face grinding and Surface grinding

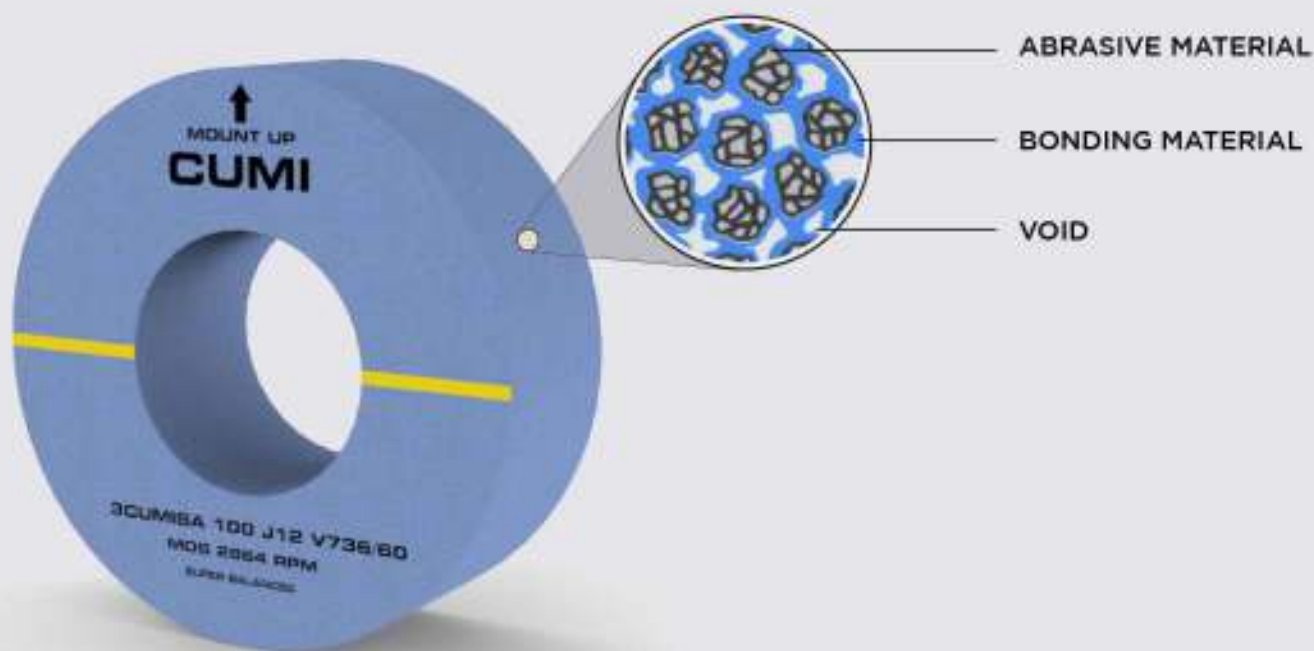

UNDERSTANDING THE NOMENCLATURE

CUMI BONDED ABRASIVES MARKING

A	46	3	L	5	V2016	/45
ABRASIVE TYPE	GRIT SIZE	GRIT COMBINATION	HARDNESS	STRUCTURE	BOND SYSTEM	WHEEL SPEED
Alumium Oxide A, AA, RA, RAA, SA, DA, HA, MCA, CUMISA	8, 10, 12, 14 16, 20, 24, 30 36, 46, 54, 60		DEFGH IJKL			
Silicon Carbide C, GC, CGC	80, 100, 120 150, 180, 220 240, 280, 320	1 3 5 7	MNOP Q RST	1 2 3 4 5 6 7 8. ..UPTO 35	V - Vitrified B - Resinoid R - Rubber	
Zircon Alumina ZA	400,600,800, 1200, 1500		UVWX YZ			

ABRASIVE GRAINS

A

46

3

L

5

V2016

/45

An Abrasive is a mineral crystal with hardness much higher than that of work piece. An Abrasive grain cuts into the work until it becomes dull. Then it breaks down (fractures) and exposes new cutting edges.

The principle properties to be considered when choosing an abrasive are as follows:

- **HARDNESS** - Resistance to Penetration
- **TOUGHNESS** - Ability to Withstand Load
- **FRIABILITY** - Ability to Fracture Under Load
- **THERMAL CONDUCTIVITY** - Ability to Conduct Heat

GRAIN TYPE	CODE	PROPERTIES & APPLICATIONS
Brown Aluminium Oxide	A	Tough grain for high tensile strength materials
Semi Friable Aluminium Oxide	SA	Free cutting grain with good form holding for complete range of steels
White Aluminium Oxide	AA	Pure Aluminium Oxide for hardened or high speed steels
Pink Aluminium Oxide	RA	Friable grain for Alloyed and Chromium Based Materials
Pink Aluminium Oxide blend	RAA	Combination of Pink and White Aluminium Oxide grains for added advantage
Ruby Pink Aluminium Oxide	24R	Tough pink grain for improved form retention
Brown and White Aluminium Oxide blend	DA	Combination of White and Brown Aluminium Oxide grains for dual advantage
Friable Aluminium Oxide	SBA	Friable grain for improved dressing
Pure Aluminium Oxide	12A	Premium grain for high performance
Premium Aluminium Oxide blend	65A	For best all round performance in cylindrical applications
Sharp Premium Aluminium Oxide blend	55A, 53A	Sharp and pure Aluminium Oxide grains for grinding hard materials
Sharp Crystal Aluminium Oxide	HA	Sharp crystalline grain combination of premium performance on all materials
Ceramic Aluminium Oxide	CUMISA	Sharp Ceramic grain for high MRR & GR requirements
Ceramic Aluminium Blend	MCA	Sharp Ceramic grain for high MRR & GR requirements
Black Silicon Carbide	C	Hard and friable grain for non ferrous material, cast iron and stainless steel
Green Silicon Carbide	GC	Hard and friable grain for grinding cemented carbide tools, hard & high chilled cast iron rolls etc
Silicon Carbide blend	CGC	Combination of C & GC
Silicon Carbide and Aluminium Oxide blend	CA	Combination of Aluminium Oxide & Silicon Carbide for Alloy steel and Stainless steel
Zirconia Alumina	AZA	Alumina Zirconia Alloy - Hard & tough grain for very high performance

GRIT SIZE

A	46	3	L	5	V2016	/45
---	-----------	---	---	---	-------	-----

The size of the abrasive grain is expressed by the size of the screen opening through which the grains are shifted or sorted. For instance, A grain or grit which goes through a screen 8 mesh or openings per linear inch is called 8 grain or grit size, while a 24 grit size is roughly twenty fourth of an inch across. The higher the grit size, the finer its type.

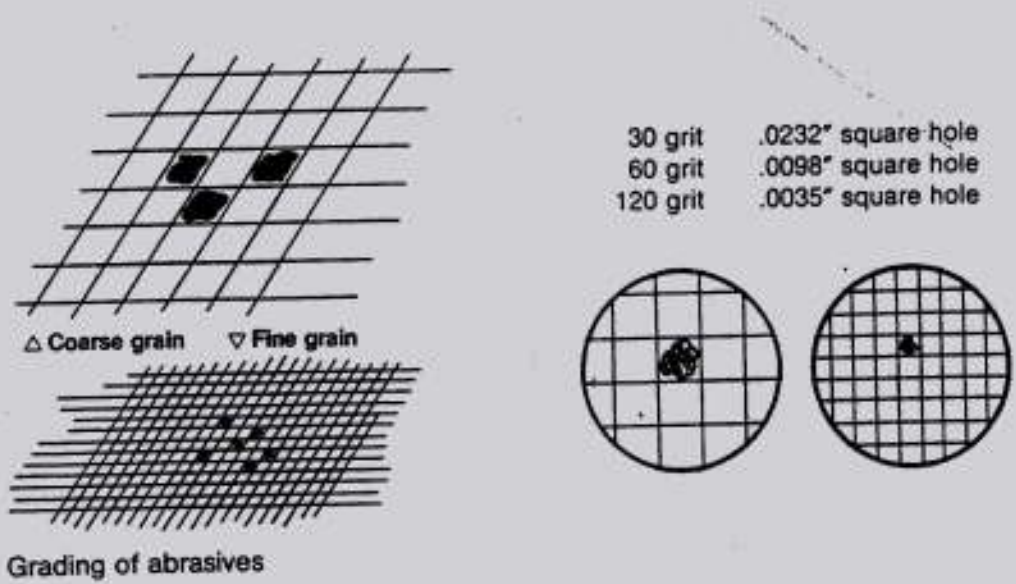

GRIT COMBINATION

A	46	3	L	5	V2016	/45
---	----	----------	---	---	-------	-----

- Combination of different grit sizes in predetermined percentages
- Ex. A463 L5 V10 - combination of 46,54& 60 grits. Primary grit 46 will be at higher percentage.

GRADE HARDNESS

A	46	3	L	5	V2016	/45
---	----	---	----------	---	-------	-----

Grade hardness is the volume of the bond present in the wheel.

For a wheel of a particular bond type, the amount of bond used in the wheel mainly determines its hardness. When the amount of bond is increased, the size of the bond posts connecting each abrasive grain to its neighbours is also increased. The larger bond post is naturally stronger, thereby increasing the wheel's hardness.

Grade hardness is therefore not a measure of the hardness of the abrasive, but of the durability of the wheel. A hard abrasive can be bonded into a soft, free cutting wheel by using less bond, while an increase in the amount of bond can make the wheel act harder. Wheel grading range from D for the softest, to Z+ for the hardest.

STRUCTURE

A

46

3

L

5

V2016

/45

Structure is an indication of the abrasive grains in a wheel. This is defined by the voids or spaces between the abrasive grain and the bonding material and is called wheel porosity. A close structured wheel is one, where the volume of closely packed grains are more. These are given structured numbers of 1 and 2. Conversely, Open structure wheels are those with wider grain spacing.



Dense Spacing



Medium Spacing



Open Spacing

Spacing of abrasive grains measured in volume of abrasive particles- higher the number, more porous the wheel structure.

5= normal porosity; 3= dense; 7=porous

DESCRIPTION	OPEN STRUCTURE	CLOSED STRUCTURE
Material Removal Rate	High	Low
Grinding Ration	Low	High
Area / Arc of Contact	High	Low
Severity of Operation	High	Low
Form Holding	Poor	Good
Wheel Speed	Low	High
Type of Operation	High stock removal, Creep Feed	Normal stock removal
Thermal conductivity of work material	Low	High

BOND

A	46	3	L	5	V2016	/45
---	----	---	---	---	--------------	-----

- The bonding material which holds the Abrasive Grains together in a wheel.
- Selection of suitable Grain, Grit size, Grade Hardness & Structure can make the wheel to work but selection of a suitable Bond plays a major role in enhancing the performance of a wheel.
- CUMI has tailor made bonds depending upon the Application, Grinding Efficiency (derived from Grinding Ratio and Specific Material Removal Rate), wheel speeds etc.

Vitrified Bond (V)	Resinoid Bond (B)	Rubber Bond (R)
Glossy Bond Made of Ingredients available Naturally	Made of Phenolic Thermo Setting Resins	Made of Natural / Synthetic Rubber
Very Brittle	Very Resilient - Can withstand shock loads	Better Resiliency - Can withstand shock loads
Water, Chemical Resistance	Low Water, Chemical Resistance	Water, Chemical Resistance
Very good Form Retention	Good Form Retention	Good Form Retention
No Shelf Life	Shelf life 1-2 Years	No Shelf Life
Severity of Operation - Low	Severity of Operation - High	Severity of Operation - High
For Wheel Speeds upto 100 metres per sec	For Wheel Speeds upto 100 metres per sec	For Wheel Speeds upto 45 metres per sec
Applicable for almost any kind of application	Gives cool cutting and is more suitable for application with high area of contact, High Material Removal Rate.	For applications where very fine surface finish is required

WHEEL SPEED

A	46	3	L	5	V2016	/45
---	----	---	---	---	-------	------------

Effect of wheel and work speed on grinding action

SPEED	INCREASED	DECREASED
Wheel speed	Harder	Softer
Work Speed	Softer	Harder
Traverse Speed	Softer	Harder
Infeed rate	Softer	Harder

WHEEL SPEED	COLOR BAND
33/35 mps	No Band
45/50 mps	Blue Band
60/63 mps	Yellow Band
80 mps	Red Band
100 mps	Green Band

WHEEL SELECTION

CUMI has one of the widest range of grinding wheels in the world. Available in standard sizes or customized to specific grinding requirements, these premier quality wheels are manufactured to suit the varied grinding needs of all user. Since there are as many types of wheels as there are grinding applications, correct wheel usage assumes very critical importance.

FACTORS AFFECTING THE SELECTION OF A GRINDING WHEEL

Wheel selection is dependent type of material to be ground and the type of grinding operation. The eight important factors that need to be considered in the selection of a grinding wheel

1. Material to be ground and its hardness
2. Stock removal and surface finish
3. The grinding process-whether wet or dry
4. Peripheral speed of the wheel
5. The area of grinding contact-large or small
6. The severity of grinding operation
7. Condition of grinding machine
8. Type of grinding machine

STANDARD GRINDING WHEEL SHAPES

STRAIGHT WHEELS

Type 1, 5 & 7 wheels are standard for internal grinding, cylindrical grinding, tool grinding, offhand grinding and snagging. The recess in Type Nos. 5 and 7 gives clearance for the mounting flanges.

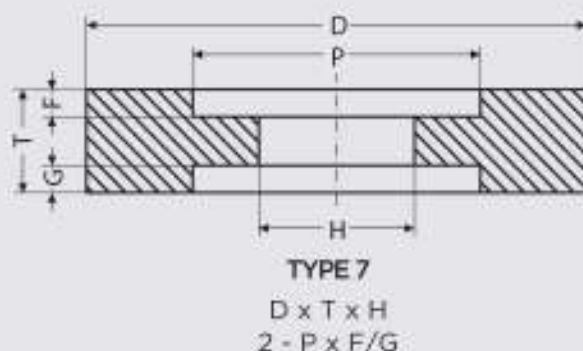
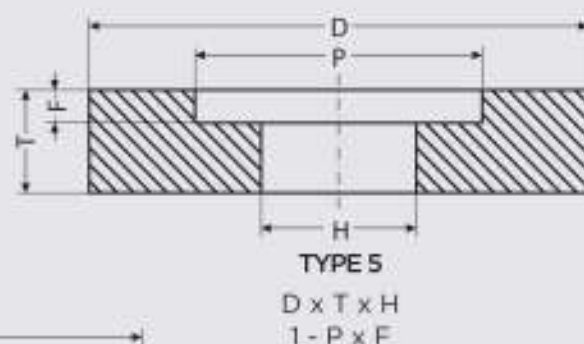
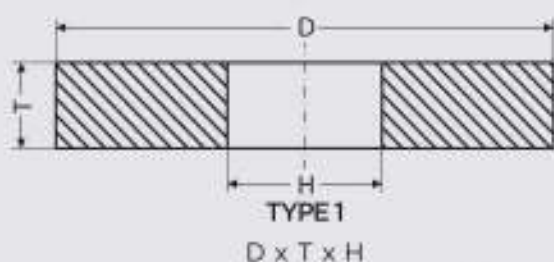

STANDARD GRINDING WHEEL SHAPES

TAPERED WHEELS

Type 4 wheel, is a modification on Type 1 wheel having a taper on both sides and is used principally in snagging operations. Tapered wheels with tapered mounting flanges are a safety device to prevent pieces of the wheel from flying out should the wheel break in operation.

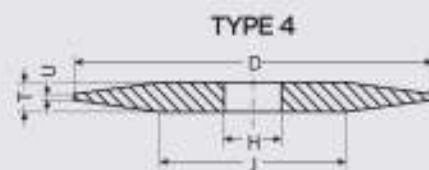

CYLINDER WHEELS

Type 2 wheel is used for surface grinding on both horizontal and vertical spindle machines with the grinding performed on the face of the wheel.

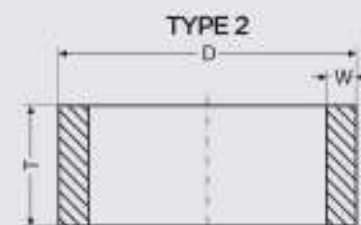

STRAIGHT CUP WHEELS

Type 6 wheel is a straight cup wheel and is used primarily for surface grinding on horizontal or vertical spindle machines. It is also useful for off-hand grinding in order to generate a flat surface. Available in either plain or bevel face.

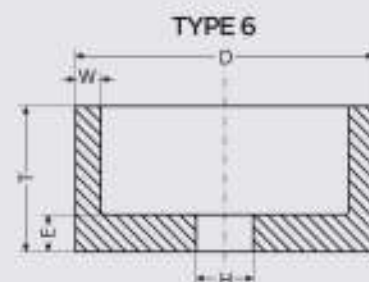

FLARING CUP WHEELS

Type 11 wheel is a flaring cup wheel used for grinding various surfaces requiring flatness. It is supplied with either a plain or bevelled face.

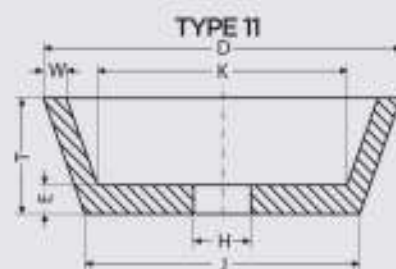

DISH WHEELS

Type 12 wheel is a dish wheel for grinding in the tool room. Its thinness permits the insertion of the grinding edge of the wheel into narrow places.

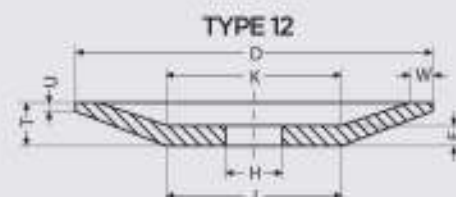

SAUCER WHEELS

Type 13 wheel is a saucer wheel or saw gummer. Its name is derived from its use for re-sharpening saws (saw gumming).

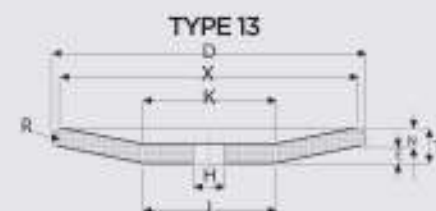

D: Diameter (overall)
 E: Thickness at hole or back thickness
 F: Depth of recess (see type 5 & 7)
 G: Depth of recess (see type 7)
 H: Hole
 J: Diameter of outside flat
 K: Diameter of inside flat

M: Large Diameter of bevel
 P: Diameter of recess
 R: Radius of corner
 T: Thickness (overall)
 U: Width of edge
 W: Wall thickness of grinding face

STANDARD GRINDING WHEEL SHAPES

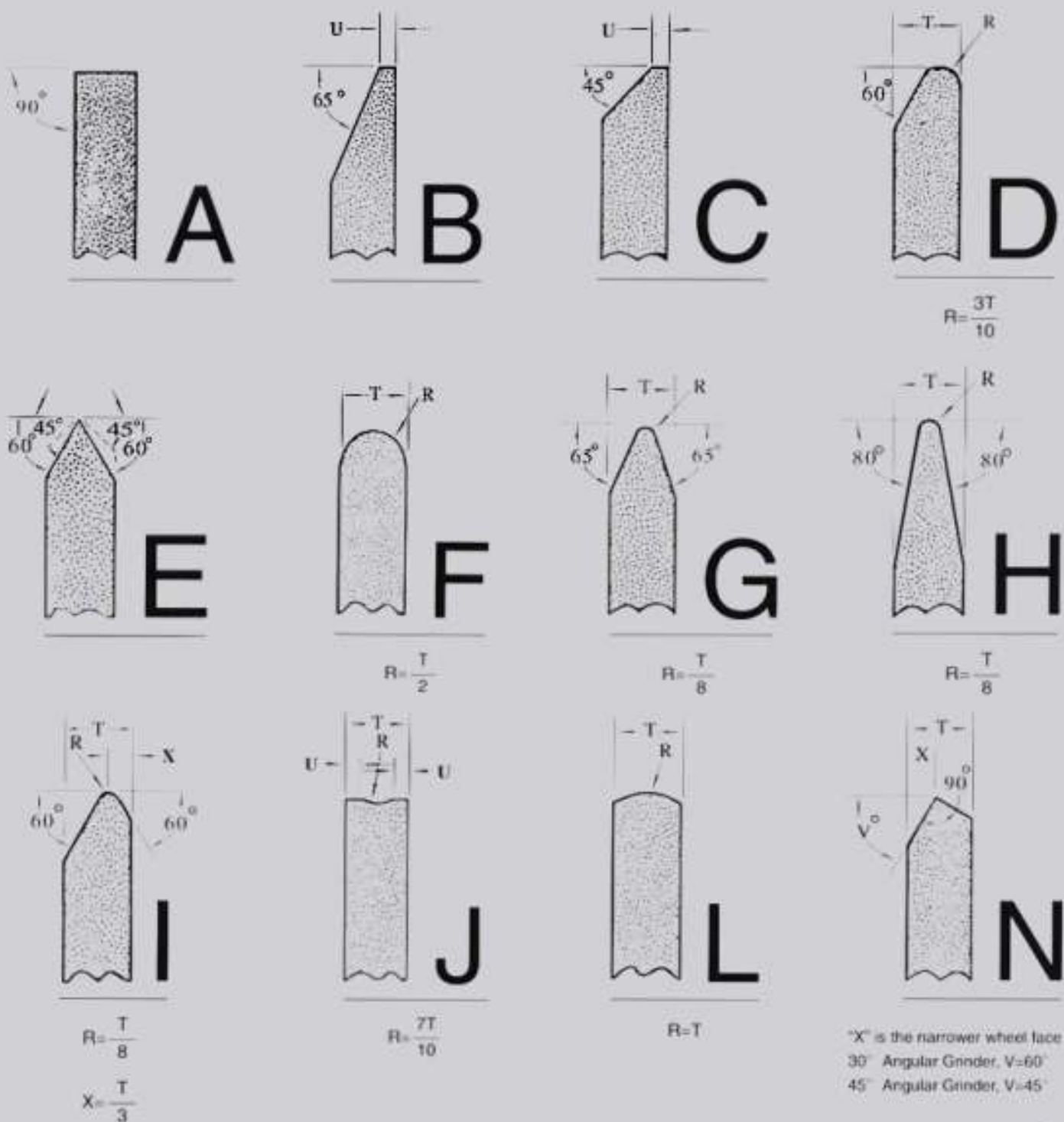

BONDED ABRASIVES CENTERLESS GRINDING WHEELS



CENTERLESS GRINDING



BONDED ABRASIVES

CENTERLESS GRINDING WHEELS

ABOUT CENTERLESS GRINDING WHEELS

An application which presents the most daunting challenges to any abrasive manufacturer. The range of requirements and priorities of this application varies from product to product which calls for an equally wide range of offerings to suit the same. Since in most of the Centerless applications, more than one wheel is mounted on the spindle, extremely tight tolerances need to be maintained in the geometry and densities of the wheels to ensure uniform wear patterns even if each wheel in the set is different.

CUMI has the expertise, when it comes to Centerless applications thanks to the advanced manufacturing process, premium Abrasive grains and specially designed Vitrified, Resin and Rubber bond systems to suit the application needs. Customized solutions are provided for every application and specific requirement. Be it through-feed, end-feed or in-feed, CUMI wheels ensure that components are finished to stringent quality requirements.

FEATURES:

- Unique set of combination wheels for higher stock removal, good surface roughness and higher productivity
- Unique grain combination for specific application
- Cork bond for superior surface roughness & lustre
- Wide range of bond system to customize individual grinding needs

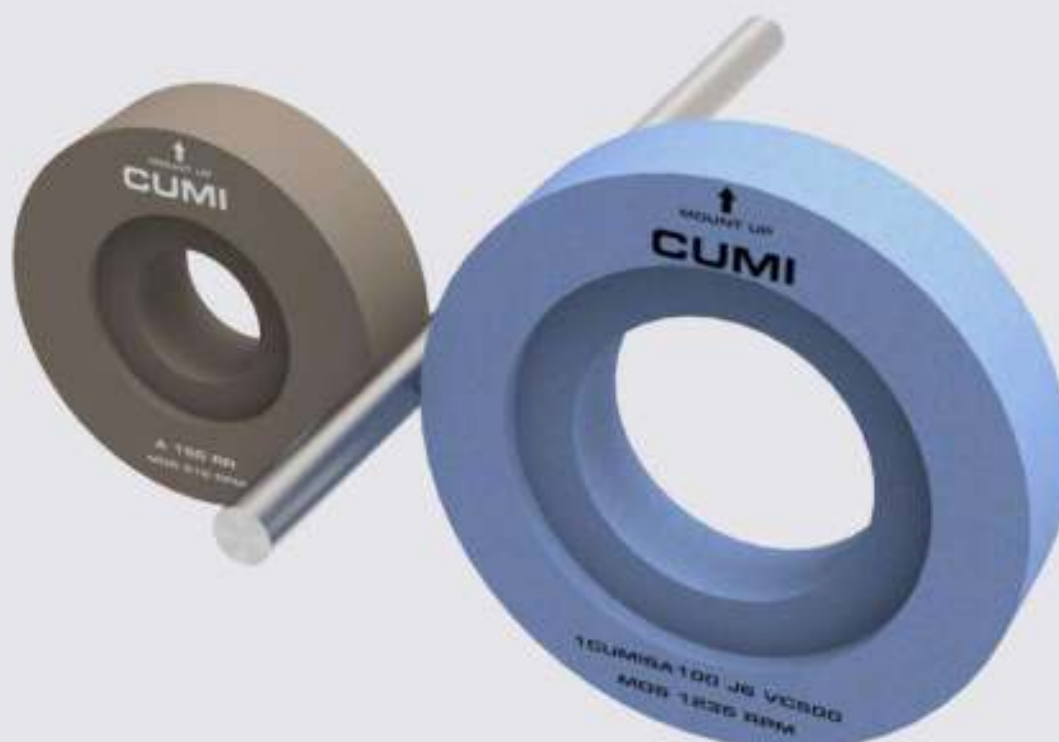

CENTERLESS GRINDING WHEELS

ADVANTAGES OF CUMI WHEELS

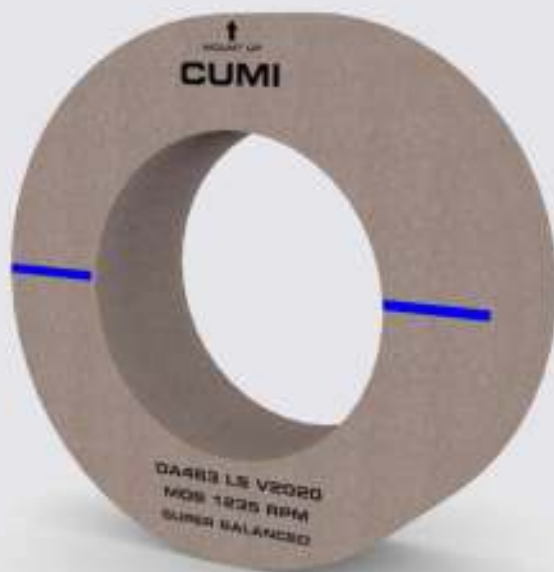

1. High stock removal
2. Lower dressing frequency
3. Burn free component
4. Better productivity
5. Excellent surface finish

WIDTH OF PRODUCT RANGE

Abrasive Used	CUMI Code	Grit Range	Diameter		Thickness		Hardness	Structure	Speed mps
			mm	inch	mm	inch			
Ceramic Aluminium Oxide	CUMISA	46 - 120					I - N	6 & 8	35, 50 & 63
Sharp Aluminium Oxide blend	53A / 55A	46 - 120					I - N	7	35 & 50
Premium Aluminium Oxide	65A	80 - 220			100 - 250	4 - 10	L	-	40
Semi friable Aluminium Oxide	SA	46 - 120	350 - 610	14 - 24			I - N	5 - 7	35 & 50
White Aluminium Oxide	AA	46 - 120					I - N	5 - 7	35 & 50
Aluminium Oxide blend	DA	46 - 120					I - P	5 - 7	35 & 50
Brown Aluminium Oxide	A	46 - 120			100 - 300	4 - 12	I - P	5 - 7	35 & 50
Black Silicon Carbide	C	46 - 120					I - P	5 - 7	35 & 50

SHAPES



COMMONLY USED MACHINES

•Cincinnati •WMW •Marcus •Lid Kopping

VALVE STEM

Type	Operation	Speed	Best	Better	Good
Mono Valve	Rough	35	DA463 M5 V500	A463 M3 V2016	A463 M3 V10
		50	DA463 M5 V500/45	A463 M3 V2016/45	A463 M3 V45
	Semi Finish	35	DA60 L5 V500	A60 L5 V2016C	A60 L5 V10C
		50	DA60 L5 V500/45	A60 L5 V2016C/45	A60 L5 V45C
	Finish	35	DA100 J5 V500	A100 J5 V2016C	A100 J5 V10C
		50	DA100 I5 V500/45	A100 I5 V2016C/45	A100 I5 V45C
Bi - Metal	Rough	35	DA543 N5 V500	A463 M3 V2016	A463 M3 V10
		50	DA543 N5 V500/45	A463 M3 V2016/45	A463 M3 V45
	Semi Finish	35	DA60 L5 V500	A60 L5 V2016C	A60 L5 V10C
		50	DA60 L5 V500/45	A60 L5 V2016C/45	A60 L5 V45C
	Finish*	35	5SA100 I5 V390	5A100 I5 V390*	A100 J5 V10C
		50	5SA100 I5 V390/45	5A100 I5 V390/45	A100 I5 V45C

* Finishing Operation :

For Roughness 0.3 Ra --> Use Grit 100

For Roughness < 0.3 Ra --> Use Grit 1001



BEARING RING

Type	Operation	Speed	Best	Better	Good
Outer Diameter Soft Stage	Rough	35	-	DA463 L5 V2020	A46/54 M5 V10
		50	-	DA463 L5 V2020/45	A46/54 M5 V45
Outer Diameter Hard Stage	Rough	35	5SA60 L5 V10C	DA60 L5 V10C	A60 L5 V10C
		50	1CUMISA60 J6 VCAE/45	DA60 K5 V45C	A60 K5 V45C
		63	1CUMISA60 J6 VCAE/60	5SA60 J5 V500/60	AA60 K5 V60
	Finish	35	5SA80 J5 V10C	DA80 J5 V10C	A80 J5 V10C
		50	1CUMISA801 I6 VCAE/45	DA80 I5 V45C	A80 I5 V45C
		63	1CUMISA801 I6 VCAE/60	5SA80 I5 V500/60	AA80 I5 V60

Note: Special Wheels

Wheel Dimension	Operation	Speed	Best	Better	Good
* 610 x 610 X 304.8 * 508 X 610 X 304.8 * 610 X 508 X 304.8	Roughing & Finishing	45	1CUMISA461 J6 VCAE/45	5A461 J5 V391/45	-
			1CUMISA541 J6 VCAE/45	5A541 J5 V391/45	-
			1CUMISA601 J6 VCAE/45	5A601 J5 V391/45	-
			1CUMISA801 I6 VCAE/45	5A801 I5 V391/45	-
	Roughing & Finishing	63	1CUMISA461 J6 VCAE/60	5A461 J5 V391/60	-
			1CUMISA541 J6 VCAE/60	5A541 J5 V391/60	-
			1CUMISA601 J6 VCAE/60	5A601 J5 V391/60	-
			1CUMISA801 I6 VCAE/60	5A801 I5 V391/60	-
* 610 X 864 X 304.8	Roughing & Finishing	35	AA46 I5 V2016	-	-
			AA60 I5 V2016	-	-
			AA80 H5 V2016	-	-



BEARING ROLLER

Type	Operation	Speed	Best	Better	Good	
Outer Diameter - Taper Roller	Rough	35	65A801 L RT1	A80 L RT3	A80 L RT1	
		50	65A801 L RT45	A80 L RT45	-	
	Finish	35	65A100 M RT1 65A120 L RT1	A120 M RT1	A100 M RT1 A120 L RT1	
		50	A400 F3 RBX A500 F3 RBX	- -	- -	
	Outer Diameter - Spherical Rollers / Cylindrical Rollers	Rough	35	1CUMISA60 J6 VCAE	53A60 J7 VC500	AA60 K5 V8
			50	1CUMISA60 J6 VC500/45	53A60 J7 VC500/45	AA60 K5 V45
Finish		35	1CUMISA80 J6 VCAE	53A80 J7 VC500	AA80 K5 V8	
		50	1CUMISA80 J6 VC500/45	53A80 J7 VC500/45	AA80 K5 V45	
Needle Roller	Rough	35	GC150 M5 VF920	-	GC150 M5 VG	
		50	GC150 M5 VF920/45	-	GC150 M5 VG/45	
	Finish	35	-	A120 M RT1	A120 L RT1	
		50	-	-	-	

* V- Vitrified; R- Rubber; RBX- Cork Rubber



PINS

Type	Operation	Speed	Best	Better	Good
Gudgeon Pin	Rough	35	1CUMISA461 K6 VCAE	AA463 L5 V2020	A463 L5 V10C
		50	1CUMISA461 K6 VC500/45	AA463 K5 V2020/45	A463 K5 V45C
	Semi Finish	35	1CUMISA601 K6 VCAE	AA60 L5 V2020	A60 L5 V10C
		50	1CUMISA601 K6 VC500/45	AA60 K5 V2020/45	A60 K5 V45C
	Finish	35	1CUMISA100 J6 VC500	AA100 J5 V2020	A100 J5 V10C
		50	1CUMISA100 I6 VC500/45	AA100 I5 V2020/45	A100 I5 V45C
	Fine Finish	35	-	A220 N5 VK12	-
	Super Finish	35	A400 F5 RBX	C320 P5 BYZ	-

* V- Vitrified; R- Rubber; RBX- Cork Rubber



SHOCK ABSORBER

Type	Operation	Speed	Best	Better	Good
Inner Tube / Fork Pipe	Rough - 1	35	55A603 N7 B99	DA603 N7 B99	A80 N7 B310
		50	55A603 N7 B99/45	DA603 N7 B99/45	A80 N7 B310/45
	Rough - 2	35	-	A120 L RT1	A1203 N8 B310
		50	-	A120 LRT1/45	A1203 N8 B310/45
	Semi Finish	35	65A220 L RT1	A220 L RT1	-
		50	65A220 L RT1/45	A220 L RT1/45	-
Finish	35	AA400/A500 G5 RCBX	-	-	
	50		-	-	
Piston Rod	Rough - 1	35	55A603 N7 B99	A801 N7 B99	A60 K5 V10C
		50	55A603 N7 B99/45	DA603 N7 B99/45	-
	Semi Finish	35	65A220 L RT1	A220 L RT1	-
		50	65A220 L RT1/45	A220 L RT1/45	-
	Finish	35	AA400/A500 G5 RCBX	-	-
		50		-	-

* V- Vitrified; R- Rubber; RBX- Cork Rubber



BRIGHT BAR

Type	Operation	Speed	Best	Better	Good
BRIGHT BAR	Rough	35	-	C463 M5 VG	A60 L5 V10C
		50	1CUMISA463 N5 B820/45	C463 N5 B820/45	-
	Finish	35	-	C601 M5 VG	-
		50	1CUMISA603 N5 B820/45	C603 N5 B820/45	-



PISTONS & LINERS

PISTON

Type	Operation	Speed	Good
Piston Ring	Rough	35	C463 L5 VG
		50	-
	Finish	35	C60 L5 VG
		50	-

LINERS

Type	Operation	Speed	Best	Better	Good
Grey Cast Iron	Rough	35	C543 J7 B190K	-	C543 K5 B190
		50	C543 J7 B190K/45	-	C543 K5 B190/45
SG Iron	Rough	35	-	C543 K5 B903	-
		50	-	C543 K5 B903/45	-



DRILLS & TAPS

Type	Operation	Speed	Best	Better	Good
Drills & Taps	Rough	35	DA463 M5 V10C	A463 L5 V446C	A463 L5 V10C
		50	DA463 M5 V45C	A463 L5 V446C/45	A463 L5 V45C
	Semi Finish	35	DA60 M5 V10C	A60 L5 V446C	A60 L5 V10C
		50	DA60 M5 V45C	A60 L5 V446C/45	A60 L5 V45C
	Finish	35	DA80 K5 V10C	A80 K5 V446C	A80 K5 V10C
		50	DA80 K5 V45C	A80 K5 V446C/45	A80 K5 V45C



FEED/REGULATING WHEELS

ABOUT FEED/REGULATING WHEELS

CUMI's regulating wheels are the best in class in the world. These wheels are made using a distinct calendaring process, leading to superlative & consistent performance making it as the most preferred product in the industry. The controlled wear not only leads to highly precise components but also gives longer life.

FEATURES:

- Tough grains for long life
- Resilient rubber for better finish

PRODUCT RECOMMENDATION

Operation	Better	Good
For finish	A80 RR	A80 RR
For size control	A120 RR	A120 RR
	A150 RR	A150 RR
For size control & better finish	A180 RR	A180 RR



BONDED ABRASIVES CYLINDRICAL GRINDING WHEELS



CYLINDRICAL GRINDING WHEELS

ABOUT CYLINDRICAL GRINDING WHEELS

CUMI's versatile range of cylindrical wheels are used for a variety of grinding operations that require size generation, fine surface finish and fast stock removal. Special wheels are also available for multiple diameters and shoulder grinding with pre-formed wheel faces.

CUMI's cylindrical grinding wheels find wide application in the grinding of valves, plunger pins, eye bolts, transmission shafts, cam shafts, crank shafts etc.,

FEATURES:

- Best choice of abrasive grain wheels for higher stock removal, higher productivity and form retention
- Customizes sketches for every customer requirement
- Wide range of bond system to customize individual grinding needs



CYLINDRICAL GRINDING WHEELS

ADVANTAGES OF CUMI WHEELS



1. High stock removal
2. Better productivity
3. Excellent surface finish
4. Lower dressing frequency
5. Burn free component

WIDTH OF PRODUCT RANGE

Abrasive Used	CUMI Code	Grit	Diameter		Thickness		Hardness	Structure	Speed mps
			mm	inch	mm	inch			
Ceramic Aluminium Oxide	CUMISA				25 - 150	1 - 6	H - M	6 - 13	35, 50 & 63
Friable Aluminium Oxide	SBA				25 - 250	1 - 10	H - M	5 - 8	35 & 50
Sharp Aluminium Oxide blend	53A				25 - 150	1 - 6	H - M	6 - 13	35 & 50
Pink Aluminium Oxide	RAA				25 - 150	1 - 6	H - M	5 - 8	35 & 50
Semi friable Aluminium Oxide	55A				25 - 150	1 - 6	H - M	5 - 8	35, 50 & 63
White Aluminium Oxide	AA	46 - 120	300 - 610	12 - 24	25 - 250	1 - 10	H - M	5 - 8	35, 50 & 63
Aluminium Oxide blend	DA				25 - 150	1 - 6	H - M	5 - 8	35 & 50
Brown Aluminium Oxide	A				25 - 150	1 - 6	H - M	5 - 8	35 & 50
Silicon Carbide blend	CGC				25 - 150	1 - 6	H - M	5 - 8	35 & 50
Green Silicon Carbide	GC				25 - 150	1 - 6	H - M	5 - 8	35 & 50
Black Silicon Carbide	C				25 - 150	1 - 6	H - M	5 - 8	35 & 50

SHAPES



COMMONLY USED MACHINES

•Landis •Schaudt •Paragon •Palmary •Norton

CYLINDRICAL GRINDING WHEELS

HIGH SPEED STEEL (HSS)

Hardness	Speed	Best	Better	Good
Low content Vanadium & Molybdenum	35	1CUMISA60 J6 VC500	RAA60 J5 VF8	AA60 K5 V8
	50	1CUMISA60 J6 VC500/45	RAA60 J5 VF8/45	AA60 K5 V45
High content Vanadium & Molybdenum	35	1CUMISA601 H12 VCA2	RAA601 H10 V736	AA601 H10 V736
	50	1CUMISA601 G12 VCA2/45	RAA601 G10 V736/45	AA601 G10 V736/45

TUNGSTEN CARBIDE

Hardness	Speed	Best	Better	Good
For all HRc	35	CGC60 K5 VG	GC60 K5 VG	C60 K5 VG
	50	CGC60 J5 VS2001/45	GC60 J5 VS2001/45	C60 J5 VS2001/45



CYLINDRICAL GRINDING WHEELS

GENERAL PURPOSE

Hardness	Speed	Best	Better	Good
< 40 HRc	35	AA463 M5 V2016	SBA463 M5 V10	A463 M5 V10
	50	1CUMISA541 L6 VC500/45	5SA463 L5 V500/45	DA463 M5 V45
	63	1CUMISA541 L6 VC500/60	AA463 L5 V60	5SA463 L5 V500/60
50 HRc to 60 HRc	35	AA463 K5 V2016	SBA463 K5 V10	A463 K5 V10
	50	1CUMISA541 J6 VC500/45	5SA463 J5 V500/45	DA463 K5 V45
	63	1CUMISA541 J6 VC500/60	AA463 J5 V60	5SA463 J5 V500/60

CAST IRON

Hardness	Speed	Best	Better	Good
< 40 HRc	35	GC463 N5 VG	CGC463 M5 VG	C463 M5 VG
	50	GC463 N5 VS2001/45	CGC463 M5 VS2001/45	C463 M5 VS2001/45
	63	-	-	-
50 HRc to 60 HRc	35	GC463 L5 VG	CGC463 K5 VG	C463 K5 VG
	50	GC463 L5 VS2001/45	CGC463 K5 VS2001/45	C463 K5 VS2001/45
	63	-	-	-

STEEL

Hardness	Speed	Best	Better	Good
< 40 HRc	35	AA463 M5 V2016	SBA463 M5 V10	A463 M5 V10
	50	1CUMISA541 L6 VC500/45	5SA463 L5 V500/45	DA463 M5 V45
	63	1CUMISA541 L6 VC500/60	AA463 L5 V60	5SA463 L5 V500/60
50 HRc to 60 HRc	35	1CUMISA541 K6 VC500	5SAA463 K5 V500	AA46/54 K5 V8
	50	1CUMISA541 K6 VC500/45	5SAA463 K5 V500/45	AA46/54 K5 V45
	63	1CUMISA541 J6 VC500/60	5SAA463 J5 V500/60	AA54 J5 V60

STAINLESS STEEL 300 SERIES

Operation	Speed	Best	Better	Good
Rough Finish	35	GC463 K5 VG	CGC463 K5 VG	C463 K5 VG
		GC80 J5 VG	CGC80 J5 VG	C80 J5 VG
Rough Finish	50	GC463 K5 VS2001/45	CGC463 K5 VS2001/45	C463 K5 VS2001/45
		GC80 J5 VS2001/45	CGC80 J5 VS2001/45	C80 J5 VS2001/45
For higher stock removal rate	Upto 35 MPS		GC60 J11 VR	

CYLINDRICAL GRINDING WHEELS

SOFT STEEL (< 40 HRc)

Operation	Hardness	Area of Contact	Best	Better	Good
Rough	35	<= 10 mm	AA46/54 L5 V8	DA 463 K5 V10	A463 K5 V10
	50		AA46/54 L5 V45	DA 463 K5 V45	A463 K5 V45
	35	> 10 mm	AA46/54 J7 V8	DA463 J7 V10	A463 J7 V10
	50		AA46/54 J7 V45	DA463 J7 V45	A463 J7 V45
Finish	35	<= 10 mm	AA60 K5 V8	DA60 K5 V10	A60 K5 V10
	50		AA60 K5 V45	DA60 K5 V45	A60 K5 V45
	35	> 10 mm	AA60 I7 V8	DA60 I7 V10	A60 I7 V10
	50		AA60 I7 V45	DA60 I7 V45	A60 I7 V45

HARD STEEL (> 40 HRc)

Operation	Hardness	Area of Contact	Best	Better	Good
Rough	35	<= 10 mm	1CUMISA60 H8 VCA2	53A60 H8 VCA2	AA60 H8 V736
	50		1CUMISA60 H8 VCA2/45	53A60 H8 VCA2/45	AA60 H8 V736/45
	35	> 10 mm	1CUMISA60 H10 VCA2	53A60 H10 VCA2	AA60 H10 V736
	50		1CUMISA60 H12 VCA2/45	53A60 H12 VCA2/45	AA60 H12 V736/45
Finish	35	<= 10 mm	1CUMISA80 H8 VCA2	53A80 H8 VCA2	AA80 H8 V736
	50		1CUMISA80 H10 VCA2/45	53A80 H10 VCA2/45	AA80 H10 V736/45
	35	> 10 mm	1CUMISA80 H12 VCA2	53A80 H12 VCA2	AA80 H12 V736
	50		1CUMISA80 H13 VCA2/45	53A80 H13 VCA2/45	AA80 H13 V736/45



BONDED ABRASIVES CRANKSHAFT GRINDING WHEELS



CRANKSHAFT GRINDING WHEELS

ABOUT CRANKSHAFT GRINDING WHEELS

What sets Crankshaft grinding apart from the other cylindrical grinding process is the extremely crucial function of the crankshaft in itself. Crankshaft design requires meticulous attention from material selection to the various hardening processes. Each part of the crankshaft is designed to have different hardness meeting specific demands of the application. Grinding of the shoulder region is a surface grinding operation, while the grinding of the pin is a cylindrical grinding operation. This poses a great challenge in designing a wheel that performs both these processes efficiently.

With the incorporation of the latest advances in Abrasive grains and Vitrified bond technology, CUMI provides Crankshaft grinding wheels that can face each of these challenges. The basic composition of the wheels are designed to give maximum life and excellent form holding while physical forms like slotted wheels, sandwich wheels, dual grade wheels etc. enable the wheels to grind without burns.

FEATURES:

- Sharp & friable aluminium oxide grains
- Low temperature fired fusible vitrified bond system
- Uniform density and hardness across wheel diameter
- Perfectly balanced
- Sandwich option for higher feed rates & improved form holding



CRANKSHAFT GRINDING WHEELS

ADVANTAGES OF CUMI WHEELS



1. Lower BV (Barhausen value)
2. Lower dressing frequency
3. No surface cracks
4. Lower cost per component
5. Good form retention
(for better radius profile)

WIDTH OF PRODUCT RANGE

Abrasive Used	CUMI Code	Grit	Diameter		Thickness		Speed	Hardness	Structure
			mm	Inch	mm	Inch			
Ceramic Aluminum Oxide	CUMISA								
Sharp Crystal Aluminum Oxide	71HA								
Semi-Friable Grain	SA								
Pure Aluminum Oxide	12A	46-80	600-1200	24 - 48	19 - 125	3/4 - 5	Up to 60	J - M	S - B
White Aluminum Oxide	AA								
Aluminum Oxide Blend	DA								
Brown aluminum Oxide	A								

SHAPES

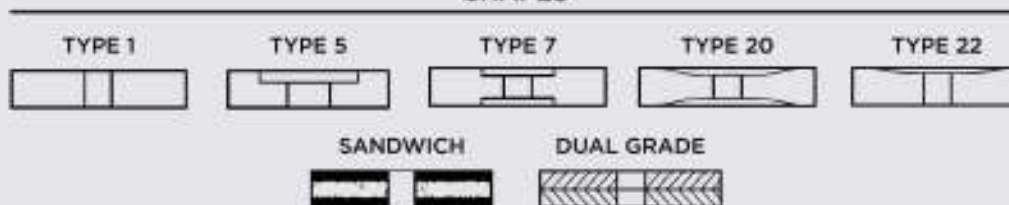

AUTO COMPONENTS

COMMONLY USED MACHINES

- Zanrosso •Lampco •Prince •Tos •Schledum •Berco
- Churchill •Landis •Ribbon •Van Roman •Storm Vulcan
- Norton •Schou •Rex

Type	Operation	Speed	Best	Better	Good	
Forged Steel	Soft	35	12A467 J7 V2020	AA463 K5 V2020	A463 L5 V10X	
		50	12A467 I7 V2020/45	AA463 K5 V2020/45	A463 K5 V45X	
		60	71HA463 H7 V2020/60	12A467 I7 V2020/60	AA463 K5 V2020/60	
	Hard - Car	35	12A601 K5 V2020	SA601 K5 V2020	A601 K5 V10X	
		50	12A601 K5 V2020/45	AA601 K5 V2020/45	DA601 K5 V2020/45	
		60	71HA601 J7 V2020/60	AA601 K5 V2020/60	SA601 K5 V2020/60	
	Hard - commercial	35	12A467 J7 V2020	AA463 K5 V2020	A463 L5 V10X	
		50	12A467 I7 V2020/45	AA463 K5 V2020/45	A463 K5 V45X	
		60	71HA463 H7 V2020/60	12A467 I7 V2020/60	AA463 K5 V2020/60	
	For Softshoulder & Hard Center Grinding	60		2CUMISA542 J+6 V500/60(Sides)	DA543 K5 V500/60(Sides) /	-
				/ AA602 J6 V500/60 (Center)	DA601 K5 V500/60(Sides)	
	Cast Iron		Up to 50	AA46 K5 V2020/45	SA46 K5 V2018/45	DA46 K5 V45
Nodular Iron		Up to 50	1CUMISA461 K6 V2020/45	AA46 L5 V2020/45	5SA46 L5 V2020/45	



CRANKSHAFT GRINDING

CUMI

BONDED ABRASIVES

BONDED ABRASIVES CAMSHAFT GRINDING WHEELS

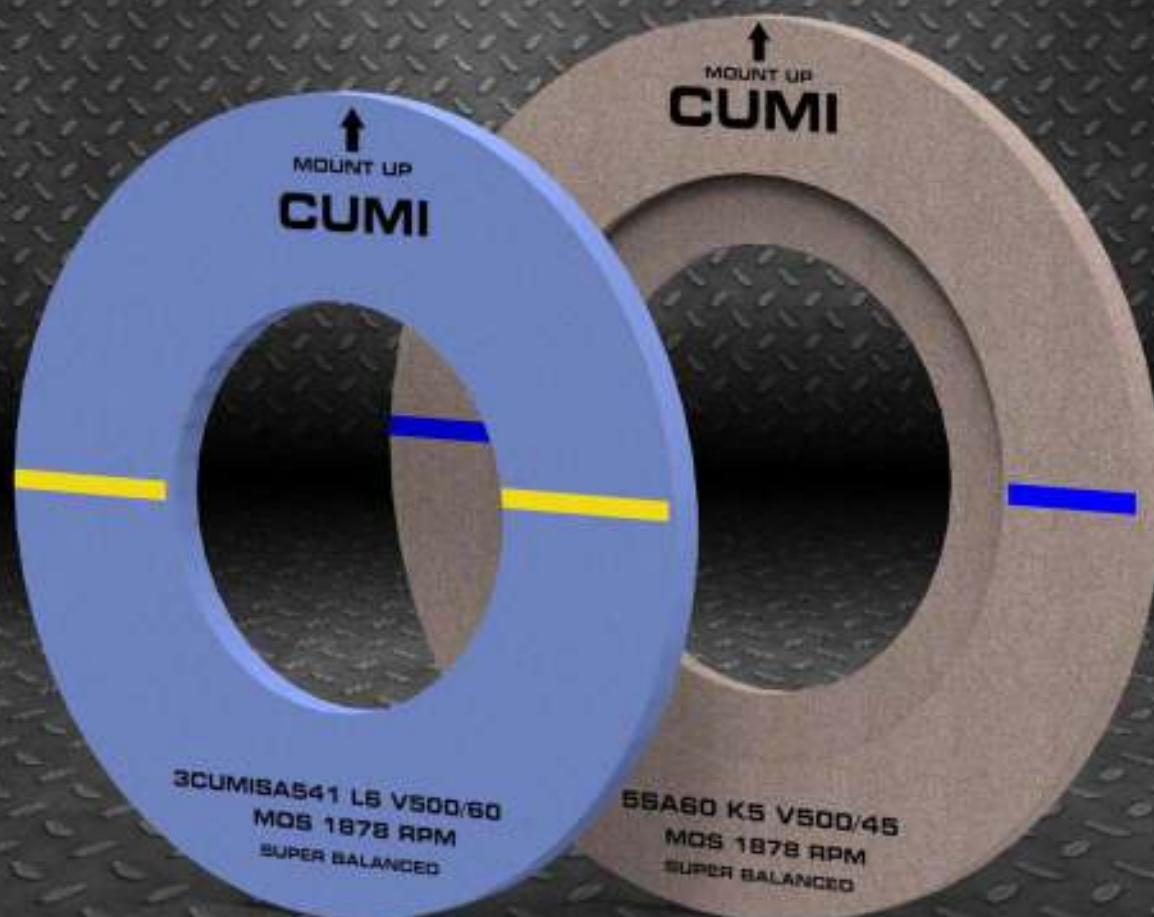

CAMSHAFT GRINDING WHEELS

ABOUT CAMSHAFT GRINDING WHEELS

CUMI's Camshaft wheels offer good form holding, free cutting ability together while maintaining the stringent geometrical and surface finish requirement to maintain consistent and tight surface finish tolerances. CUMI's versatile camshaft wheels can grind materials like forged steel and chilled cast iron with highest amount of stock removal without thermal damage on the cam flank.

CUMI also offers single wheel for both roughing and finishing operations

FEATURES:

- Sharp & friable Aluminium Oxide grains
- Vitrified Krystal bond system(V500)
- Uniform density and hardness across wheel diameter
- Perfectly balanced



CAMSHAFT GRINDING WHEELS

ADVANTAGES OF CUMI WHEELS



1. High productivity
2. Excellent form retention
3. Dimensional accuracy
4. Surface finish
5. Form accuracy

WIDTH OF PRODUCT RANGE

Abrasive Used	CUMI Code	Grit	Diameter		Thickness		Speed	Hardness	Structure
			mm	inch	mm	inch			
Ceramic Aluminium Oxide	CUMISA								
Semi friable Aluminium Oxide	SA	54 - 80	500 - 610	20 - 24	25 - 40	1 - 1 1/2	45, 60	J - M	S - B
White Aluminium Oxide	AA								
Brown Aluminium Oxide	A								

SHAPES



AUTO COMPONENTS

COMMONLY USED MACHINES

•Landis •Naxos Union •Schaudt •Fortuna



CAM LOBE (upto 60 MPS)

Type	Operation	Best	Better	Good
Case Hardened Steel	Rough	1CUMISA541 K6 VC500/60	5SA54 K5 V500/60	AA54 K5 V60
	Finish	1CUMISA801 J6 VC500/60	5SA80 J5 V500/60	AA80 I5 V60
	Rough & Finish	3CUMISA80 R20 BH99/60	1CUMISA80 R20 BH99/60	1CUMISA542 L6VC500/60
Nodular Iron	Rough	3CUMISA461 L6 V500/60	5SA463 L5 V500/60	AA463 L5 V2020/60
	Finish	3CUMISA801 J6 VC500/60	5SA80 J5 V500/60	AA80 I5 V60
Chilled Cast Iron	For Base Circle Diameter <= 25mm	3CUMISA80 R20 B99/60	5SA80 L5 V500/60	AA80 L5 V2020/60
	For Base Circle Diameter > 25mm	3CUMISA80 R23 B99/60	5SA801 J5 V500/60	AA801 J5 V2020/60

AUTO COMPONENTS



CAM JOURNAL (upto 45 MPS)

Type	Operation	Best	Better	Good
Case Hardened Steel	All Operations	1CUMISA601 J6 VC500/45	5SA60 K5 V500/45	A601 K5 V45
Nodular Iron	Rough	1CUMISA80 K6 VC500/45	5SA801 K5 V500/45	AA80 L5 V45



BONDED ABRASIVES F TYPE GRINDING WHEELS

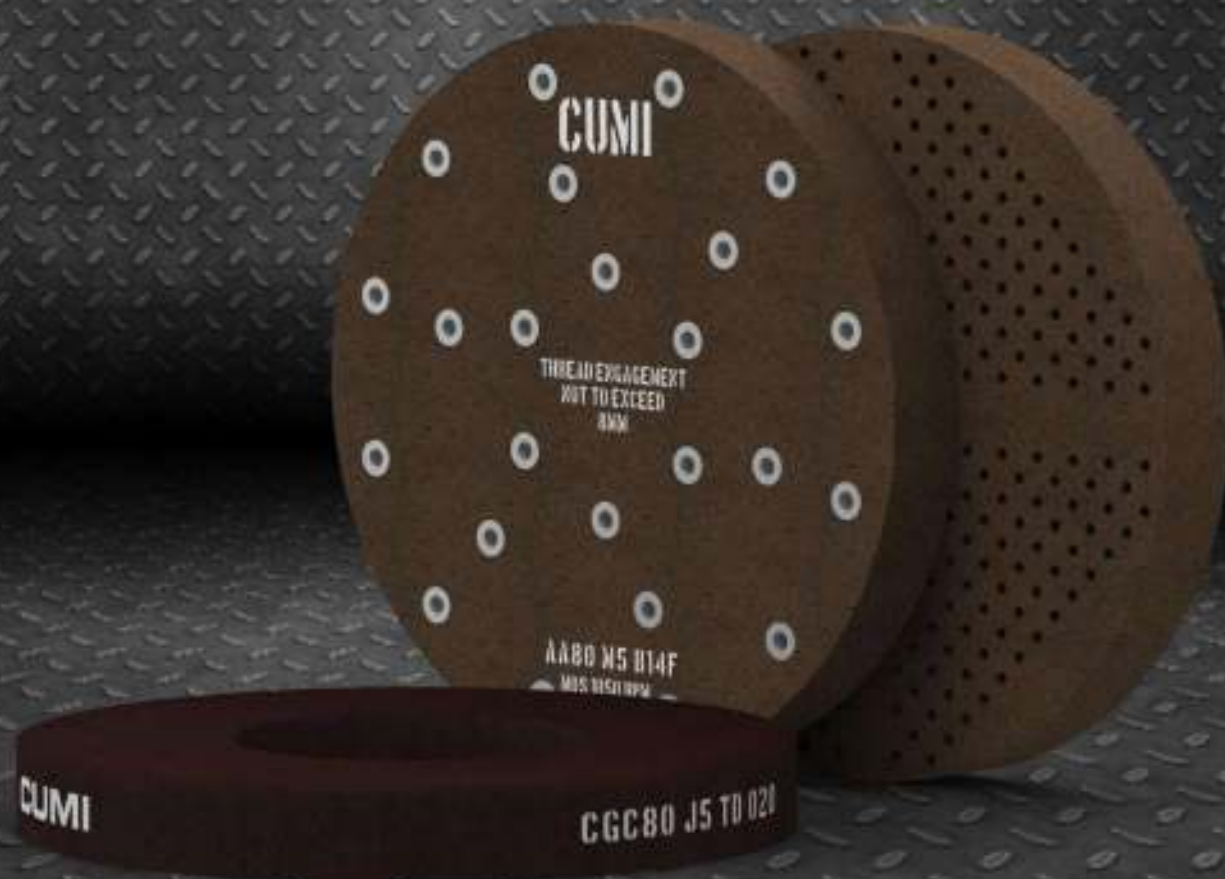

F TYPE GRINDING WHEELS

ABOUT F TYPE GRINDING WHEELS (DOUBLE DISC)

F type wheels or Fastening type wheels are resinoid wheels which are fastened to the back plates using bolts. The face of the wheel is used to grind components and generate flat and parallel surfaces. Used in various industries like Bearings, Auto etc. The applications usually demand high stock removal along with tight size tolerances and fine surface finishes. Since the area of grinding is very large, heat generation is high, provisions are made in the chemical and physical design of the wheel to ensure that there is enough scope for heat dissipation by effective utilization of coolants.

CUMI wheels are proven to perform at high feed rates and material removal applications while meeting stringent quality requirements in terms of size tolerances, heat generation and surface finishes, thanks to the special technology of grain-bond combination, which ensures free cutting. Physical features like coolant slots, through holes and honeycomb structure aid in taking the performance of the wheels to the next level.

FEATURES:

- Wide range of bonds including phenolic, magnesite and polyester
- Huge variety of high performance products using Aluminium oxide, Silicon carbide, micro-crystalline and mono crystalline grains
- Engineered design modifications comprising honey comb, slots, dual grade



F TYPE GRINDING WHEELS

ADVANTAGES OF CUMI WHEELS



1. Free cutting action
2. Less dressing frequency
3. Good surface finish
4. Excellent feed rate
5. Excellent surface quality

WIDTH OF PRODUCT RANGE

Abrasive Used	CUMI Code	Grit	Diameter		Thickness		Speed mps	Hardness	Structure
			mm	inch	mm	inch			
Ceramic Aluminium Oxide	CUMISA	16 - 150	150 - 1000	6 - 40	50 - 120	2 - 5	33	G - O	5 - 10
Semi friable Aluminium Oxide	SA	24 - 220							
White Aluminium Oxide	AA	20 - 500							
Green Silicon Carbide	GC	24 - 500							
Black Silicon Carbide	C	24 - 500							
Brown Aluminium Oxide	A	24 - 600							

AUTO COMPONENTS



CONNECTING ROD



PISTON RING



SPRING

CONNECTING ROD

Type	Operation	Best	Better	Good
Forged steel	Rough	3CUMISA46 K7 BSP	5SA46 K7 BSP	AA46 K7 BRT
	Finish	3CUMISA60 K7 BSP	5SA60 K7 BSP	AA60 K7 BRT
Sintered	Rough	3CUMISA46 J5 B43R	5SA46 J5 B43R	AA46 J5 B43R
	Finish	3CUMISA60 J5 B43R	5SA60 J5 B43R	AA60 J5 B43R

PISTON RING

Type	Operation	Best	Better	Good
Cast Iron	Rough	-	GC60 J5 BIOCS	CGC46/60 J5 TD1020M
	Semi Finish	-	CGC80 J5 BIOCS	CGC80 J5 TD1020
	Finish	-	GC/RA120 H5 TDR845	GC120 TDR659
	Lapping	-	-	C150 J5 BRT

SPRING

Type	Operation	Best	Better	Good
Spring Steel	Rough	2CUMISA24 N7 B266	AA20 L7 TDV819M* & A24 N7 B266	A24 L7 TDR085
	Finish	2CUMISA30 O7 B266	AA24 K7 TDV820M & A30 O7 B266	A24 L7 TDR086
	Rough & Finish (Single Head)	2CUMISA24 N7 B266	A36 TDR933	DA24 TDR699

*Magnesite bonded wheels

AUTO COMPONENTS



ENGINE BLOCK



SINTERED COMPONENT

ENGINE BLOCK

Type	Operation	Best	Better	Good
Cast Iron (For passenger Car)	Rough - Rotary Table	-	C24 L5 SPL	C24 K5 BRT
	Finish - Rotary Table	-	C80 L6 SPL	C120 K5 BRT
Cast Iron (For Heavy Commercial Vehicle)	Rough & Finish	-	-	C14 TDR3I2

SINTERED COMPONENT

Type	Operation	Best	Better	Good
Sintered	Rough	-	-	GC46 B056
	Finish	-	-	GC80 B056



BEARING INDUSTRY

PRODUCT RECOMMENDATION



BALL BEARING RING



TAPER ROLLER RING

BALL BEARING RING

Type	Operation	Best	Better	Good
Bearing steel	Rough & Finish	57A80 M5 B10CS	55A80 M5 B10CS	AA80 M5 B14F

TAPER ROLLER BEARING RING

Type	Operation	Best	Better	Good
Bearing steel	Big Face	57A46 G7 BRT	-	AA60 G7 BRT
	Small Face	57A60 M5 BRT	-	AA60 L5 BRT & A80 K B1190

TAPER ROLLER

Type	Operation	Best	Better	Good
Bearing steel	Face Grinding	-	-	A320 P19 BCC

BEARING INDUSTRY

CYLINDRICAL ROLLER

Type	Operation	Best	Better	Good
Bearing steel	Soft Stage	AA60 L5 SPL	-	A60 05 BRT
	Hard Stage		5SA80 L5 B14F	AA80 K5 BRT



BONDED ABRASIVES BORE GRINDING WHEELS



BORE GRINDING



BONDED ABRASIVES

BORE GRINDING WHEELS

ABOUT BORE GRINDING WHEELS

Internal or Bore Grinding wheels are used for grinding inner diameter of bearing, gears & automobile components to an accurate size & desired finish.

CUMI's versatile range of bore grinding wheels are used for grinding a variety of components that require size generation, fine surface finish and fast stock removal. We also offer value added services like sulphur treatment for lubrication & cooler cutting action.

FEATURES:

- Sharp aluminium oxide grains for excellent cutting action
- Krystal bond for form holding(V500)
- Available in various shapes

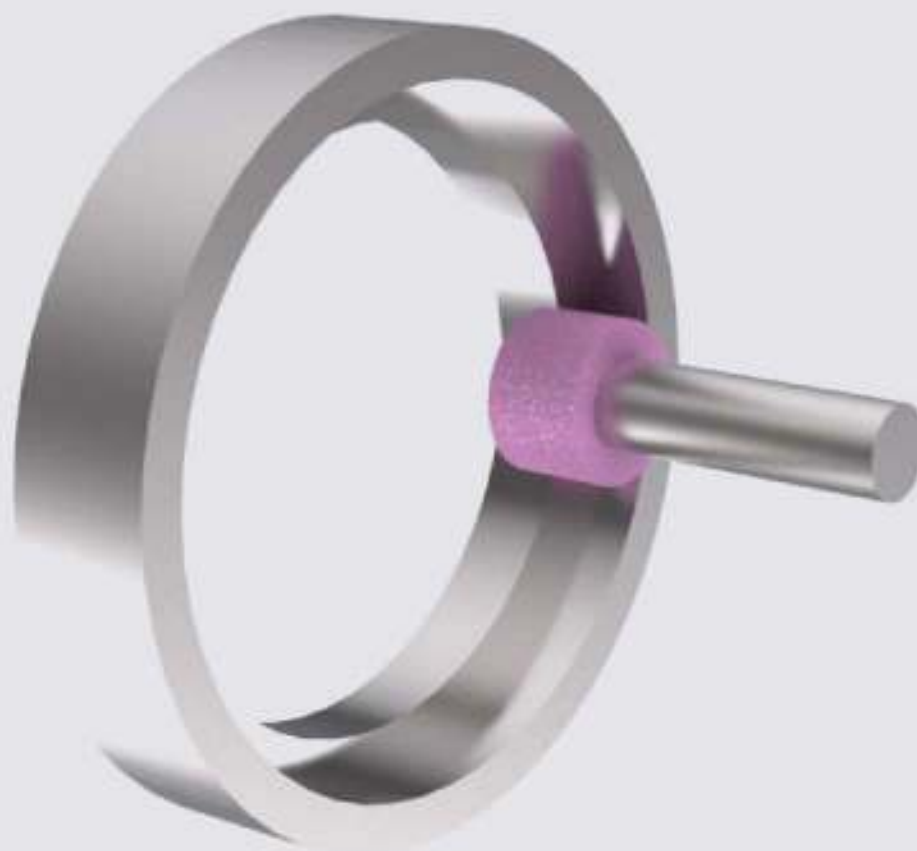

BORE GRINDING WHEELS

ADVANTAGES OF CUMI WHEELS

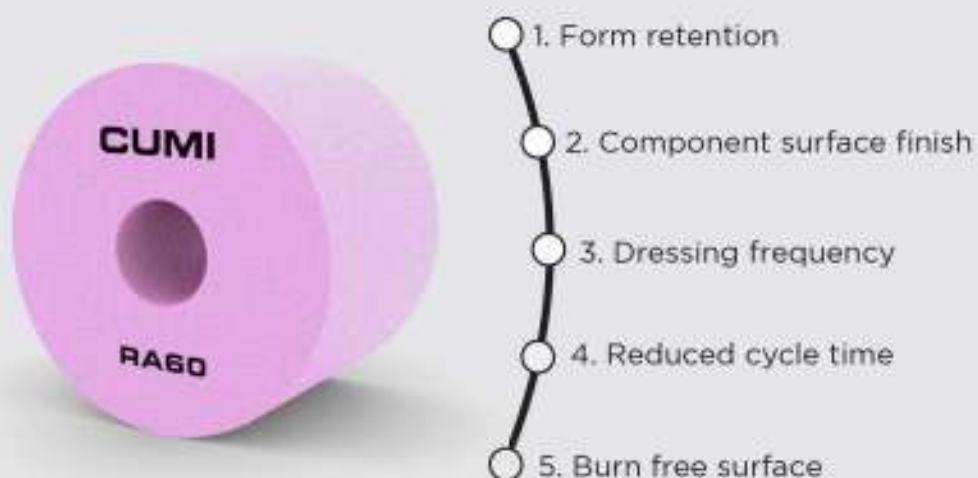

WIDTH OF PRODUCT RANGE

Abrasive Used	CUMI Code	Grit	Diameter		Thickness		Hardness	Structure	Speed mps
			mm	inch	mm	inch			
Ceramic Aluminium Oxide	CUMISA							6 - 8	
Sharp Crystal Aluminium Oxide	73HA							7	
Sharp Aluminium Oxide blend	55A	60 - 120	10 - 125	3/8 - 5	5 - 75	1/5 - 3	I - M	7	33, 50 & 63
Semi friable Aluminium Oxide	SA							5 - 8	

BEARING INDUSTRY

Material	Hardness	Bearing I.D (mm)	Speed	Best	Better	Good
Taper Roller Bearing (TRB)	55 - 60 HRc	≤ 70	upto 45	3CUMISA60 K6 V500	55A60 K7 VC500	5A60 L7 V144
			63	73HA60 J7 VC500	3CUMISA60 J6 V500	55A60 J7 VC500
		> 70	upto 45	3CUMISA80 J6 V500	55A80 J7 VC500	5A80 K7 V144
			63	73HA80 I7 VC500	3CUMISA80 J6 V500	55A80 J7 VC500



BONDED ABRASIVES IR TRACK GRINDING WHEELS



IR TRACK GRINDING WHEELS

ABOUT IR TRACKING WHEELS

With all the latest advancements in the field of automobiles and machine manufacturers, the functions of bearings are now more crucial than ever before, thereby placing greater demands on quality of bearings.

Track grinding wheels must maintain form to ensure profile accuracy of the track of inner ring. This ensures that the wheels are dressed less often, leading to significant improvement in productivity and consistency of the process.

CUMI's Track grinding wheels are made with a special fusible glassy bond with sharp abrasive grain combination that ensures form holding while offering high material removal rates in a high contact area application. An advanced manufacturing process ensures that the wheel's hardness is consistent through the wheel life and highest levels of safety are maintained.

FEATURES:

- Sharp crystal aluminium oxide grains
- Krystal bond for form holding & Safety
- Customized profiling as per requirement



IR TRACK GRINDING WHEELS

ADVANTAGES OF CUMI WHEELS



1. Profile holding & form retention
2. Dressing frequency
3. Burn free component
4. Surface finish (0.3-0.4 Ra)
5. Roundness (<math><5Q</math>)

WIDTH OF PRODUCT RANGE

Abrasive Used	CUMI Code	Grit	Diameter		Thickness		Speed mps	Hardness	Structure
			mm	inch	mm	inch			
Ceramic Aluminium Oxide	CUMISA								
Sharp Aluminium Oxide blend	55A								
Sharp Crystal Aluminium Oxide	71HA								
Semi friable Aluminium Oxide	SA	60 - 150	350 - 610	14 - 24	10 - 40	3/8 - 1 1/2	35, 50, 63, 80, 100	I - L	5 - 7
White Aluminium Oxide	AA								
Aluminium Oxide blend	DA								
Brown Aluminium Oxide	A								

BEARING INDUSTRY



BALL BEARING RING

TAPER ROLLER RING

Bearing Type	Bearing Size	Speed	Best	Better	Good
Taper Roller Bearing (TRB)	up to 50mm	35	AA120 L5 VFB	DA120 L7 V1092	A120 L7 V1092
		50	55A120 K7 VC500/45	AA120 K5 V45	DA120 K7 V1092/45
		63	3CUMISA120 K7 V389/60	71HA120 K7 VC500/60	AA120 K5 V60
		80	3CUMISA120 J7 V389/80	71HA120 J7 VC500/80	55A120 K6 V792/80
		100	3CUMISA120 J6 V792/100	-	55A120 K6 V792/100
	Above 50mm	35	AA100 L5 VFB	DA100 L7 V1092	A100 L7 V1092
		50	55A100 K7 VC500/45	AA100 K5 V45	DA100 K7 V1092/45
		63	3CUMISA100 K7 V389/60	71HA100 K7 VC500/60	AA100 K5 V60
		80	3CUMISA100 J7 V389/80	71HA100 J7 VC500/80	55A100 J6 V792/100
		100	3CUMISA100 J6 V792/100	-	55A100 J6 V792/100
Ball Bearing	All	35	55A120 L7 VC500	AA120 L5 VFB	DA120 L7 V1092
		50	55A120 K7 VC500/45	AA120 K5 V45	DA120 K7 V1092/45
		63	B3A1001 J6 V308C/60	71HA1001 K7 VC500/60	AA100 K5 V60
		80	B3A1001 I6 V308C/80	71HA1001 J7 VC500/80	55A1001 J7 VC500/80
		100	3CUMISA120 J6 V792/100	-	55A120 K6 V792/100



PRODUCT RECOMMENDATION

Bearing Type	Bearing Size	Speed	Best	Better	Good
Taper Roller Bearing (TRB)	up to 50mm	35	AA120 L5 VF8	DA120 L7 V1092	A120 L7 V1092
		50	55A120 K7 VC500/45	AA120 K5 V45	DA120 K7 V1092/45
		63	3CUMISA120 K7 V389/60	71HA120 K7 VC500/60	AA120 K5 V60
		80	3CUMISA120 J7 V389/80	71HA120 J7 VC500/80	55A120 K6 V792/80
		100	3CUMISA120 J6 V792/100	-	55A120 K6 V792/100
	Above 50mm	35	AA100 L5 VF8	DA100 L7 V1092	A100 L7 V1092
		50	55A100 K7 VC500/45	AA100 K5 V45	DA100 K7 V1092/45
		63	3CUMISA100 K7 V389/60	71HA100 K7 VC500/60	AA100 K5 V60
		80	3CUMISA100 J7 V389/80	71HA100 J7 VC500/80	55A100 J6 V792/100
		100	3CUMISA100 J6 V792/100	-	55A100 J6 V792/100
Ball Bearing	ALL	35	55A120 L7 VC500	AA120 L5 VF8	DA120 L7 V1092
		50	55A120 K7 VC500/45	AA120 K5 V45	DA120 K7 V1092/45
		63	83A1001 J6 V308C/60	71HA1001 K7 VC500/60	AA100 K5 V60
		80	83A1001 I6 V308C/80	71HA1001 J7 VC500/80	55A1001 J7 VC500/80
		100	3CUMISA120 J6 V792/100	-	55A120 K6 V792/100



BONDED ABRASIVES THREAD GRINDING WHEELS



THREAD GRINDING WHEELS

ABOUT THREAD GRINDING WHEELS

Being a high speed, high material removal application with stringent demands on the thread profile, generating threads on taps and drills by grinding isn't an easy job.

CUMI's Thread grinding wheels are formulated with high purity, Sharp Aluminium Oxide grains combined with a special glassy, fusible bond. This ensures excellent form retention of the wheel, which translates into consistent thread profile of components.

FEATURES OF THREAD GRINDING WHEELS

- Hi performance hard, sharp & friable Aluminium Oxide abrasive blend
- Fusible, glassy crystalline bond for improved form holding
- Special manufacturing process for uniform hardness across diameter

FEATURES OF THREAD ROLL DIE GRINDING WHEELS

- High purity closely graded Green Silicon Carbide micro grits
- Special Low temperature fired Vitrified bond for improved form holding
- Special manufacturing process for uniform hardness across wheel thickness



THREAD GRINDING WHEELS

ADVANTAGES OF CUMI WHEELS



1. Excellent form holding leading to reduced dressing
2. Low grinding forces
3. Minimal thermal load/
No burns on the taps
4. Lower cycle time
5. Higher wheel life

WIDTH OF PRODUCT RANGE

Abrasive Used	CUMI Code	Grit	Diameter		Thickness		Speed mps	Hardness	Structure
			mm	inch	mm	inch			
Ceramic Aluminium Oxide	CUMISA	120 - 400	200 - 510	8 - 20	6 - 40	1/4 to 1 1/2	upto 80	I - M	4 - 10
Sharp Aluminium Oxide blend	55A								
White Aluminium Oxide	AA								
Pink Aluminium Oxide	RA								



THREADED TAP

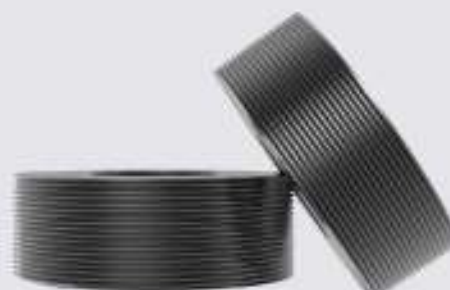

THREAD ROLL DIE

THREAD GRINDING WHEELS

Thread (pitch, mm)	Best	Better	Good
0.4–0.7	1CUMISA400 K9 VF920/80	-	AA400 K9 VF920/80
0.8–1.0	1CUMISA320 K9 VF920/80	-	AA320 K9 VF920/80
1.25 – 1.5	1CUMISA280 L10 V457/80	-	AA280 L10 V457/80
1.75 – 2.0	1CUMISA240 L9 V457/80	55A220 L9 V457/80	AA240 L9 V457/80
2.25	1CUMISA220 M9 V457/80	RA220 M9 V457/80	AA220 M9 V457/80
2.50 - 3.00	1CUMISA180 M9 V457/80	RA180 M9 V457/80	AA180 M9 V457/80
3.25 -4.00	1CUMISA150 M9 V457/80	RA150 M9 V457/80	AA150 M9 V457/80

THREAD ROLL DIE GRINDING WHEELS

Thread (Pitch, mm)	TPI	Grading
0.7	36	GC400 I5VFG72
0.8	32	
1	25	GC320 I5 VFX72
1.25	20	
1.5	17	GC280 I5 VFG72
1.75	15	
2	13	GC220 I5 VFG72
2.5	10	
3.5	7	
4	6	

BONDED ABRASIVES FLUTE GRINDING WHEELS

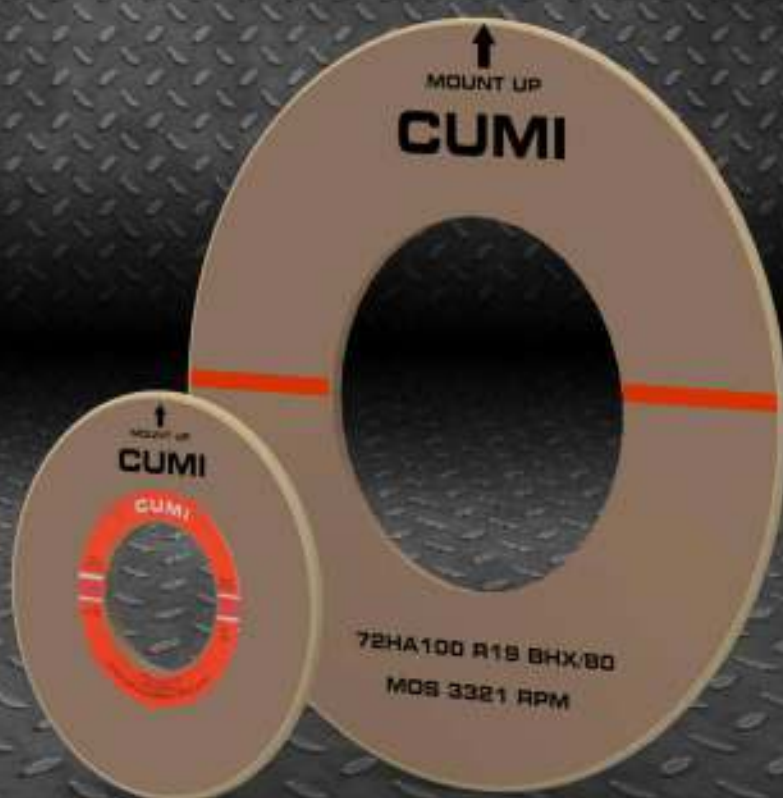

FLUTE GRINDING WHEELS

ABOUT FLUTE GRINDING

Being a high depth of cut, form generating grinding process, Flute grinding operations are at high speeds and remove material at rates comparable to machining process rather than grinding. A combination of peripheral and surface grinding actions, the depth of cut, width of cut, form retention and surface finish are crucial parameters.

CUMI Flute grinding wheels are specially engineered high density (near zero porosity), resin bonded wheels which ensure that the form is generated with utmost precision and finesse. These wheels truly are a testament to the expertise that CUMI has built over the years.

FEATURES:

- Special phenolic resin
- Specially treated aluminium oxide grains for higher depth of cut
- Micro crystalline grain for lesser dressing frequency
- Unique manufacturing process for high density packing



FLUTE GRINDING WHEELS

ADVANTAGES OF CUMI WHEELS



1. High depth of cut
2. Higher wheel life
3. Better form holding/
reduced dressing
4. Smoke free grinding
5. Burn free components

WIDTH OF PRODUCT RANGE

Abrasive Used	CUMI Code	Grit	Diameter		Thickness		Face	Coolant slot	Speed mps
			mm	inch	mm	inch			
Ceramic Aluminium Oxide	CUMISA								
Sharp Crystal Aluminium Oxide	72HA								
Semi friable Aluminium Oxide	SA	80 - 150	150 - 500	6 - 20	4 - 20	0.16 - 0.8	F	Slotted	80
Pink Aluminium Oxide	RA								
White Aluminium Oxide	AA								

FLUTE GRINDING WHEELS

COMMONLY USED MACHINES

•Hertline •Normac •Gefra



DRILL



TAP

Operation	Component	Size	Best	Better	Good
Flute grinding	Drill	16" x T x 5"	72HA100 R19 BHX/80	3CUMISA100 R19 BHX/80	AA100 R19 BHK/80
		16" x T x 8"	72HA100 R19 BH99/80	3CUMISA100 R19 BH99/80	3SA80 R19 BHX/80
		18" x T x 8"			3SA80 R19 BH99/80
Flute grinding	Taps	6" x T x 3"	72HA80 R20 BHX/80	3CUMISA80 R20 BHX/80	RA80 R19 BHK/80
		8" x T x 3"	72HA80 R20 BH99/80	3CUMISA80 R20 BH99/80	
		12" x T x 3"	72HA80 TDR366/80	3CUMISA80 TDR366/80	
		16" x T x 5"			
Point grinding	Drills	10" x T x 1.25"	-	-	AA100 S12 BHP/60 AA100 S12 BH47/80
Clearance grinding	Drills	10" x T x 1.25"			AA80 Q21 BH99/80
		8" x T x 1.25"	72HA100 R344/80	3CUMISA100 R344/80	AA100 R344/60
		12" x T x 5"			-

T - Thickness Range - 0.14" to 2.0"

BONDED ABRASIVES BALL GRINDING & LAPPING WHEELS



BALL GRINDING & LAPPING WHEELS

ABOUT BALL GRINDING & LAPPING WHEELS

The demands expected of balls in the Bearing industry have become highly stringent in terms of quality in the recent years. The primary objective of a ball manufacturer is to constantly improve quality of the balls, in terms of sphericity (roundness) and surface finish, while reducing the overall manufacturing cost.

CUMI provides best-in-class ball finishing solutions, customized to meet the exacting demands and ensure that premium quality balls are produced. Be it the High Density Vitrified wheels for Grinding or the Micro grit Resinoid wheels for Lapping, CUMI has got it all. The state of the art manufacturing facility ensures that every wheel produced meets stringent quality norms.

FEATURES

BALL GRINDING

- Conditioned and specially treated raw materials
- Unique bond system for defect free surface
- Specially controlled process for ensuring consistency (layer to layer & wheel to wheel)

BALL LAPPING

- Closely graded aluminium oxide grain for superior surface quality
- Unique inside out hot press technology for ensuring consistency
- Modified resins to achieve high material removal rate and low wheel wear



BALL GRINDING WHEELS

ADVANTAGES OF CUMI WHEELS



1. Faster cycle time
2. Consistent quality layer to layer
3. Longer wheel life
4. Superior ball quality
5. Overall low grinding cost per ball

WIDTH OF PRODUCT RANGE

Abrasive Used	CUMI Code	Grit Range	Diameter		Thickness		Hardness	Toughness
			mm	inch	mm	inch		
Black Silicon Carbide	C	80 - 200	300 - 1000	12 - 40	40 - 140	1-1/2 to 5-1/2	V, X & Z	1, 3 & 5
		280 - 400	300 - 600	12 - 24	40 - 100	1-1/2 to 4		1 & 3



BALL INDUSTRY

PRODUCT RECOMMENDATION

Operation	Ball Size		Grit Range	Good	Better	Best
	mm	inch				
Rough	<= 4mm	<= 5/32"	400, 320	-	C - VB	10C - VB
	> 4mm - 11mm	> 5/32" - 7/32"	280, 220 & 180			
	12mm - 25mm	15/32" - 31/32"	180, 150 & 120			
	> 25mm	> 31/32"	100 & 80			

Grinding Ratio	Hardness
Low	V
Medium	X
High	Z

Material Removal Rate	Toughness
High	1
Medium	3
Low	5

BALL LAPPING WHEELS

ADVANTAGES OF CUMI WHEELS



1. Unique process for product consistency
2. Longer wheel life
3. Excellent surface finish
4. Reduced lapping cost
5. Higher productivity due to high material removal rate

WIDTH OF PRODUCT RANGE

Abrasive Used	CUMI Code	Grit Range	Diameter		Thickness		Hardness	Structure
			mm	inch	mm	inch		
Silicon Carbide & White Aluminium Oxide blend	CA	320 - 1500	400 - 1000	16 - 40	30 - 140	1-1/4 to 5-1/2	Y, Z & Z+	4
Ceramic Aluminium Oxide blend	MCA	320 - 1500	400 - 1000	16 - 40	30 - 80	1-1/4 to 3-1/4	Y, Z & Z+	
White Aluminium Oxide	AA	320 - 1500	400 - 1000	16 - 40	30 - 80	1-1/4 to 3-1/4	Y, Z & Z+	



BALL INDUSTRY

PRODUCT RECOMMENDATION

Operation	Lapping Stage	Grit Range	Hardness	Best	Better	Good
Lapping	1	600 & 800	Y, Z & Z+	MCA-BL11	CA-BL393	-
	2	800 & 1000	Y, Z & Z+		CA-BL393S	
	3	1200 & 1500	Y & Z		AA-BL11	

Bond	Advantages
BL393	High MRR
BL393S	High GR
BL11	High MRR & GR

Grinding Ratio	Hardness
Low	Y
Medium	Z
High	Z+



BONDED ABRASIVES CREEP-FEED GRINDING WHEELS



CREEP-FEED GRINDING WHEELS

ABOUT CREEP-FEED GRINDING WHEELS

Very high grinding allowances, and at the same time, superior surface finish requirements on the components; Although easy to describe, what is challenging in this application is the ability to maintain form, size and finish produced by the wheels while removing very high amount of stock.

CUMI offers Creep-feed grinding wheels which are designed to perform well in high material removal operations without compromise on the form and finish. Be it continuous dressing or conventional intermediate dressing, when it comes to Creep-feed grinding, CUMI wheels achieve reduced dressing by superior form holding while removing material at high feed rates.

FEATURES

- Free cutting abrasives
- Fusible, glassy bond for improved form holding
- Uniform large open pores for coolant flooding
- Advanced moulding technique for uniform mass distribution
- Low temperature processing to retain abrasive hardness



CREEP-FEED GRINDING WHEELS

ADVANTAGES OF CUMI WHEELS



1. High feed rates for faster cycle time
2. Controlled wear and longer wheel life
3. Burn free surface
4. Easy on the Dressing roll
5. Good form holding leading to good geometry and dressing

WIDTH OF PRODUCT RANGE

Abrasive Used	CUMI Code	Grit	Diameter		Thickness		Speed mps	Hardness	Structure
			mm	inch	mm	inch			
Semi - Friable Grain	SA								
White Aluminium Oxide	AA	46 - 120	300 - 610	12 - 24	20 - 150	3/4 - 6	33	E - 1	16 - 28
Pure Aluminium Oxide	12 A								

SHAPES



AEROSPACE

Material	Component	Best	Better	Good
Inconel 718	Fir Tree, Buckets	1CUMISA603 E28 VC2020	AA603 E28 V2020Y	5SA803 E28 V2020

AUTOMOTIVE

Material	Component	Best	Better	Good
Alloy Steel	TP Rotor	1CUMISA802 E29 VC500	12A100 E29 VCOOL	AA100 F26 VMC
	TO BE FILLED	1CUMISA802 E29 VC500	5SA802 F26 VCOOL	AA80 F26 VMC
	Steering Rack	1CUMISA463 E28 VC2020	5SA463 F28 V2020	AA46 F26 VMC
	Racker Arm	1CUMISA463 E28 VC2020	5SA463 F28 V2020	AA46 F26 VMC
	Machine Guideway	5SA463 F28 V2020	RAA463 J23 VMPA	AA46 J16 VF8P

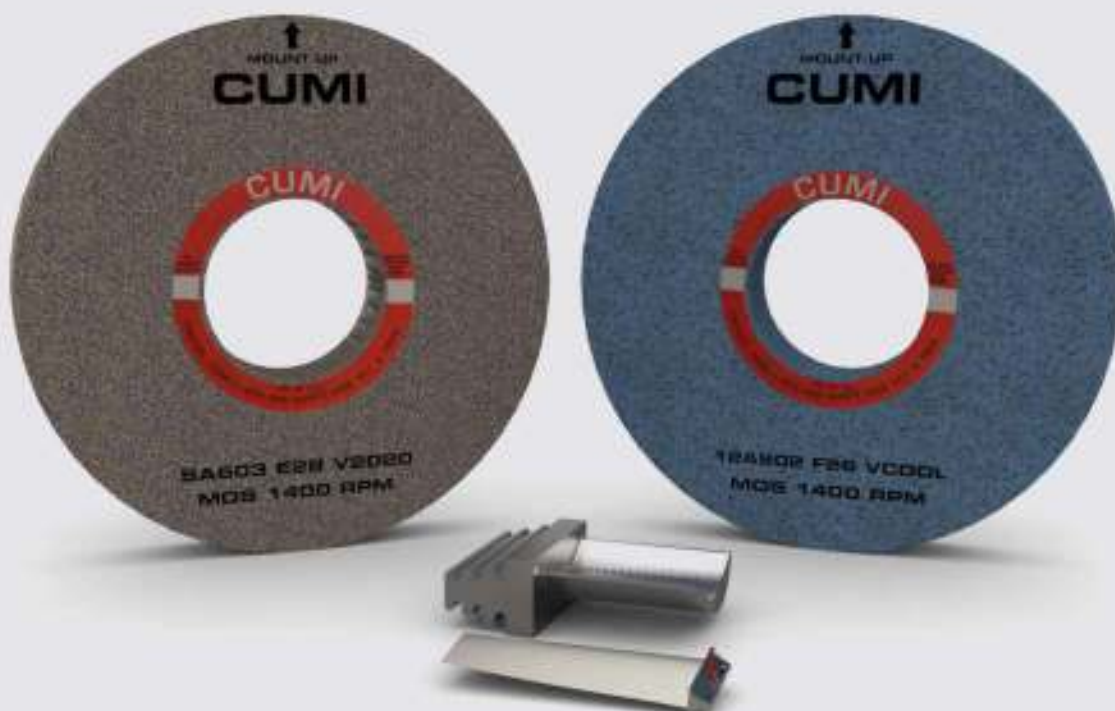

BONDED ABRASIVES GEAR GRINDING WHEELS



GEAR GRINDING



BONDED ABRASIVES

GEAR GRINDING WHEELS

ABOUT GEAR GRINDING WHEELS

One of the most advanced grinding applications, the sheer amount of parameters that are measured/controlled during the grinding of gears poses enough of a challenge to give abrasive manufacturers a run for their money. Intricate profile accuracy while maintaining high Material removal rates (Q') and Dressing frequency (V') are the major requirements in this application.

CUMI's Specially designed sharp crystalline grain combination and Krystal bond systems enable us to predict wheel wear patterns and thereby modify our wheels to ensure that the necessary profile and surface roughness is achieved consistently while maintaining low cycle times. While the combination ensures performance, our world class manufacturing set up makes sure that all the varieties of gear grinding like single rib, multi rib, bevel etc. are covered.

FEATURES

- High performance Sharp, Microcrystalline abrasive blended with friable abrasives
- Fusible, glassy crystalline bond for improved form holding
- Special filling, pressing and sintering process for uniform hardness across width
- High precision CNC profiling of wheel and inspection

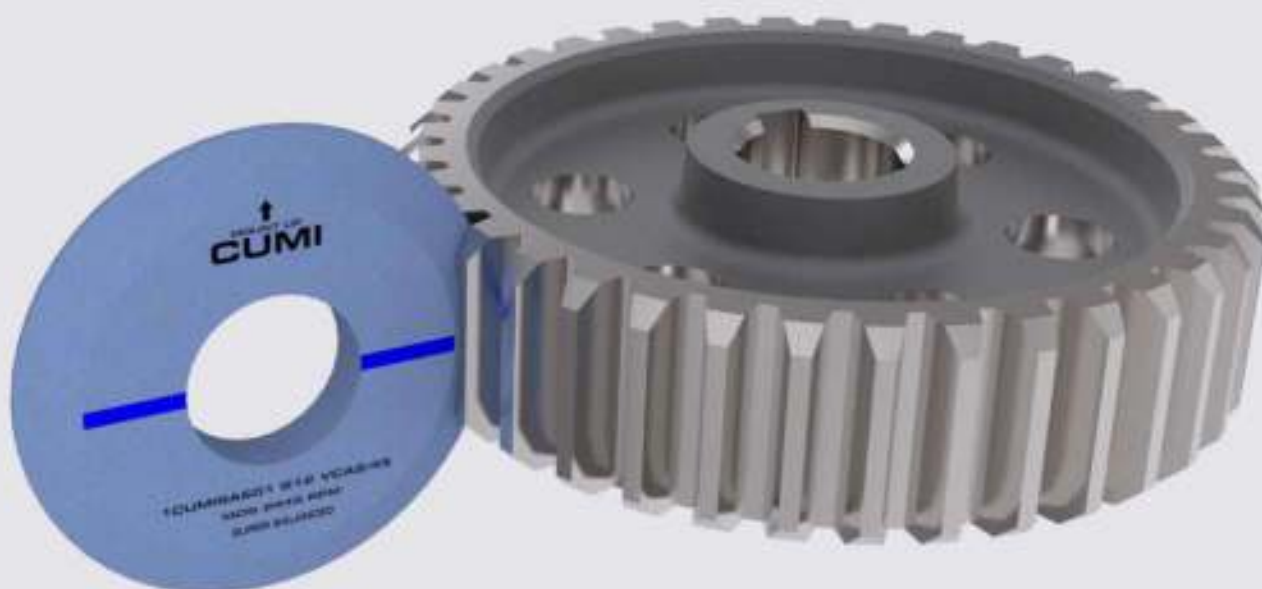

GEAR GRINDING WHEELS

ADVANTAGES OF CUMI WHEELS



1. Burn free surface
2. High feed rates - Q'
3. Reduced dress depth and frequency
4. Good form holding for profile accuracy
5. Controlled wear and highly consistent performance throughout working life

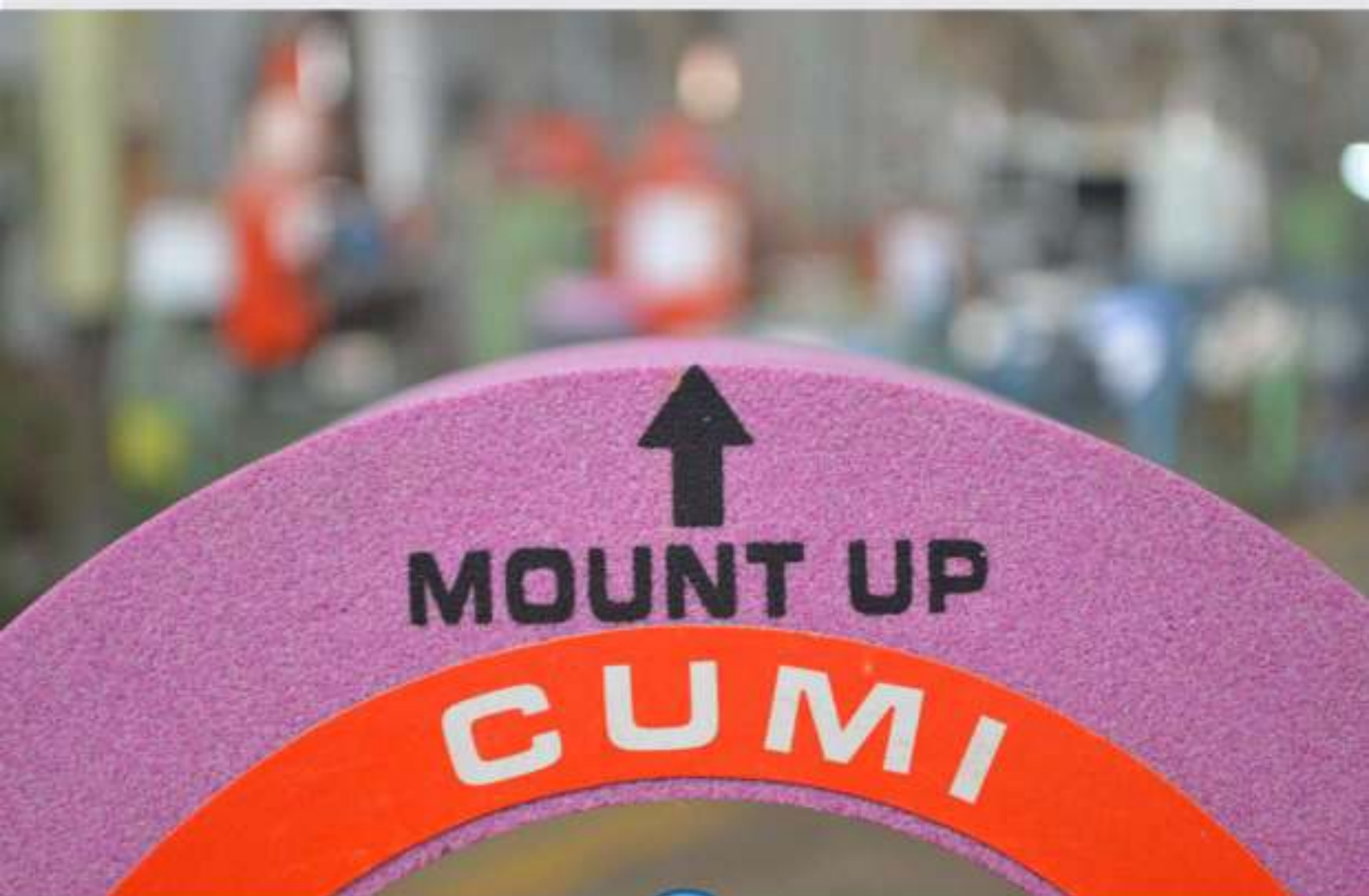

SINGLE RIB GEAR GRINDING

WIDTH OF PRODUCT RANGE

Abrasive Used	CUMI CODE	Grit Range	Diameter		Thickness		Hardness	Structure	Speed mps
			mm	inch	mm	inch			
Ceramic Aluminium Oxide	CUMISA	46 - 120	80 - 508	3 1/4 - 20	10 - 150	3/8 - 6	G - J	8 - 15	35 & 50
Sharp crystal Aluminium Oxide	71HA								
Sharp Aluminium Oxide blend	55A								
Pink Aluminium Oxide	RAA								

COMMONLY USED MACHINES

•Niles •Hafler •Maag

CONVENTIONAL PROCESS

Gear Module	Stock Removal	Best	Better	Good
Upto 8 M	Upto 5Q'W	1CUMISA601 G12 VCA2/45	55A601 G12 VCA2/45	RAA60 H10 V736/45
	6Q' to 8Q'W	71HA601 G13 VCA2/45	3CUMISA601 G13 VCA2/45	1CUMISA601 G12 VCA2/45
	Above 8Q'W	71HA601 G18 VCA2/45	3CUMISA601 G18 VCA2/45	1CUMISA601 G15 VCA2/45
Above 8 M	Upto 5Q'W	71HA601 G13 VCA2/45	3CUMISA601 G13 VCA2/45	1CUMISA601 G12 VCA2/45
	6Q' to 8Q'W	71HA601 G18 VCA2/45	3CUMISA601 G18 VCA2/45	1CUMISA601 G15 VCA2/45
	Above 8Q'W	71HA601 G21 VCA2/45	3CUMISA601 G21 VCA2/45	1CUMISA601 G18 VCA2/45



SINGLE RIB GEAR GRINDING

COMMONLY USED MACHINES

•Gleason •Pfauter •Samputensili •Hofler •Niles

CNC PROCESS

Gear Module	Stock Removal	Best	Better	Good
Upto 5 M	Upto 5Q'W	71HA601 G13 VCA2/45	3CUMISA601 G13 VCA2/45	1CUMISA601 G12 VCA2/45
	6Q' to 8Q'W	73HA601 G15 VCA2/45	71HA601 G13 VCA2/45	3CUMISA601 G13 VCA2/45
	Above 8Q'W	73HA601 G15 VCA2/45	71HA601 G13 VCA2/45	3CUMISA601 G13 VCA2/45
6 - 10 M	Upto 5Q'W	73HA601 G15 VCA2/45	71HA601 G13 VCA2/45	3CUMISA601 G13 VCA2/45
	6Q' to 8Q'W	73HA601 G18 VCA2/45	71HA601 G15 VCA2/45	3CUMISA601 G15 VCA2/45
	Above 8Q'W	73HA601 G21 VCA2/45	71HA601 G18 VCA2/45	3CUMISA601 G18 VCA2/45
Above 10 M	Upto 5Q'W	73HA601 G18 VCA2/45	71HA601 G15 VCA2/45	3CUMISA601 G15 VCA2/45
	6Q' to 8Q'W	73HA601 G21 VCA2/45	71HA601 G18 VCA2/45	3CUMISA601 G18 VCA2/45
	Above 8Q'W	-	-	-

MULTI RIB GEAR GRINDING

WIDTH OF PRODUCT RANGE

Abrasive Used	CUMI CODE	Structure	Speed mps	Grit Range	Diameter		Thickness		Hardness
					mm	inch	mm	inch	
Ceramic Aluminium Oxide	CUMISA	10 - 13	50, 63 & 80	60 - 120	250 - 400	10 - 16	80 - 250	3 1/4 - 10	I - K
Sharp Crystal Aluminium Oxide	7IHA								
Sharp Aluminium Oxide blend	55A								
Ruby Pink Aluminium Oxide	24R								
Pink Aluminium Oxide	RA	5 - 7	35 & 50	60 - 180					
Semi friable Aluminium Oxide	SA	5 - 7							

COMMONLY USED MACHINES

- Reishauer (ZB/OZA/AZA/NZA)

CONVENTIONAL PROCESS

Gear Module	Best	Better	Good
upto 1.5 M	1CUMISA280 TDV547/45	-	RA280 TDV547/45
1.75 M - 2.25 M	3CUMISA80 I12 V736/45	55A80 I10 V736/45	SA100 I7 V677/45
2.5 M - 4 M	3CUMISA80 I12 V736/45	55A80 I10 V736/45	SA80 K5 V677/45
Above 4.25 M	3CUMISA60 J12 V736/45	55A60 J10 V736/45	SA60 K5 V677/45

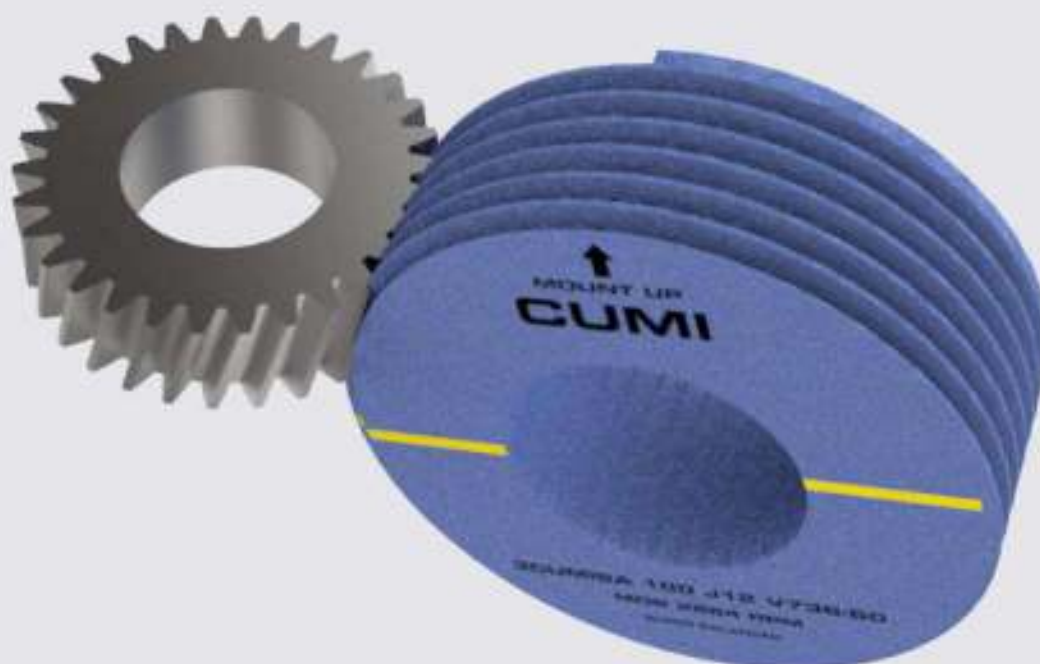

MULTI RIB GEAR GRINDING

COMMONLY USED MACHINES

- Reishauer RZ301S, RZ361S, RZ362A
- Liebherr (LCS200 / LC280)
- Kapp •Gleason •Pfauter •Samputensili

CNC PROCESS

Gear Module	Best	Better	Good
upto 1.5 M	3CUMISA120 I12 V736/45	55R120 J12 V736/45	24R120 J12 V736/45
1.75 M - 2.25 M	3CUMISA100 J12 V736/45	55R100 J12 V736/45	24R100 J12 V736/45
2.5 M - 4 M	3CUMISA80 J12 V736/45	55R80 J12 V736/45	24R80 J12 V736/45
Above 4.25 M	3CUMISA60 K12 V736/45	55R60 K12 V736/45	24R60 K12 V736/45

COMMONLY USED MACHINES

- Reishauer RZ400, RZ150, RZ1000
- Leibherr (LCS200/LC280)

CNC (Creepfeed Type) PROCESS - 60mps

Gear Module	Best	Better	Good
upto 1.5 M	73HA120 I13 V736/60	71HA120 I12 V736/60	3CUMISA120 I12 V736/60
1.75 M - 2.25 M	73HA100 I13 V736/60	71HA100 I12 V736/60	3CUMISA100 I12 V736/60
2.5 M - 4 M	73HA80 I13 V736/60	71HA80 I12 V736/60	3CUMISA80 J12 V736/60

SHAVING CUTTER

WIDTH OF PRODUCT RANGE

Abrasive Used	CUMI CODE	Hardness	Structure	Grit Range	Diameter		Thickness		Speed mps
					mm	inch	mm	inch	
Sharp Aluminium Oxide blend	53A	G - I	10 - 13	100 - 120	750-800	29 1/2 - 31 1/2	20-50	3/4 - 2	35
White Aluminium Oxide	AA	I - K	5 - 8						
Pink Aluminium Oxide	RA								

COMMONLY USED MACHINES

- Hurth

Process	Best	Better	Good
Shaving Cutter	53A120 G13 VCA2	RA120 G6 TDV155	AA100 18 VMPA



HONING & HOB RE-SHARPENING

WIDTH OF PRODUCT RANGE

Abrasive Used	CUMI CODE	Hardness	Structure	Grit Range	Diameter		Thickness		Speed mps
					mm	inch	mm	inch	
Ceramic Aluminium Oxide	CUMISA	I - K	6 - 8	80 - 220	80 - 508	3 1/4 - 20	10 - 50	3/8 - 2	35 & 50
Sharp crystal Aluminium Oxide	73HA	G - J	10 - 15						
Pink Aluminium Oxide blend	RAA								

COMMONLY USED MACHINES

- Prawema •SyncroFine •Gleason-Hurth •Fassler
- Seiwa •Emag •Kapp •Kanzaki Power

Type	Specification
Vitrified honing	CUMISA220 V894
Epoxy resin honing	CUMISA180 E895

Type	Best	Better	Good
Hob Re-sharpening	73HA60 G12 V736/45	3CUMISA80 J6 V500/45	RAA60 H10 V736/45



BONDED ABRASIVES ROLL GRINDING WHEELS



ROLL GRINDING WHEELS



BONDED ABRASIVES

ROLL GRINDING WHEELS

ABOUT ROLL GRINDING WHEELS

Although a simple cylindrical grinding application, what makes Roll grinding challenging is the volume of stock removed from rolls, which are difficult to grind. The length of roll also provides a challenge for the wheel to retain its size and form during the traverse grinding process. Maintaining high grinding ratios/ roll reduction values is crucial in these applications, as they have a direct effect on the overall cost and cycle time.

CUMI Roll Grinding wheels combine the latest developments in resin bond technology along with suitable grain combination to give the optimal balance between cutting action and wheel life without compromising on the quality parameters.

FEATURES

- Hi performance Microcrystalline abrasive blended with Silicon Carbide grains
- Special phenolic resins for high wear resistance
- Modular manufacturing facility
- Controlled curing process



ROLL GRINDING WHEELS

ADVANTAGES OF CUMI WHEELS



1. High feed rates for faster cycle times
2. Controlled wear (High Grinding ratios)
3. Excellent surface quality
4. Spiral & Scratch free finish for Cold rolling applications
5. Consistent performance throughout working life

WIDTH OF PRODUCT RANGE

Abrasive Used	CUMI Code	Grit	Diameter		Thickness		Speed	Hardness	Structure
			mm	inch	mm	inch			
Ceramic Aluminium Oxide	CUMISA								
Semi friable Aluminium Oxide	SA								
White Aluminium Oxide	AA	36 - 120	610 - 1100	24 - 44	60 - 150	2-1/4 to 6	45	I - K	5 - 7
Green Silicon Carbide	GC								
Brown Aluminium Oxide	A								

SHAPES



STEEL

HOT STRIP MILL

Type of Roll	Best	Better	Good
Work Roll	3CUMISA36 B344S/45 For ICDP & HSS	1CUMISA36 B344S/45 For ICDP & HSS	GC361 B112R/45 For good cutting (upto 120 microns infeed)
	3CUMISA36 J5 BWG/45 For ICDP	1CUMISA36 J5 BWG/45 For ICDP	GC46 B206/45 For optimum cutting & life (upto 100 microns infeed)
	3CUMISA36 J5 BWH/45 For HSS	1CUMISA36 J5 BWH/45 For HSS	GC361 B1139/45 For longer life (upto 80 micros infeed)
Back up Roll	-	3SA36 I5 B14/45	A36 J5 B384/45

COLD ROLLING MILL

Type of Roll	Best	Better	Good
Work Roll	3CUMISA60 K5 B384GR/45	3AA60 K5 B384GR/45	AA60 K5 B384GR/45
Back up Roll	-	AA60 K5 B384W/45	A60 K5 B384W/45



ROLL GRINDING

CUMI

BONDED ABRASIVES

BONDED ABRASIVES SNAGGING WHEELS



SNAGGING WHEELS



BONDED ABRASIVES

SNAGGING / FETTLING WHEELS

ABOUT SNAGGING / FETTLING WHEELS

One of the roughest and toughest applications in the industry, snagging operations focus primarily on the material removal rates. With high wheel speeds and manual grinding involved, the product design calls for robustness that gives utmost safety while addressing the material removal requirements of the user.

CUMI wheels stand up to this tough task, thanks to a rugged combination of specially formulated resins and toughened grains. The reinforced bores ensure that the product is extremely safety use in spite of the rugged nature of the applications

FEATURES:

- Rounded, tough abrasives
- Strong and tough resin bond for durability
- Grinding aids for cool cutting
- High accuracy finishing of wheels for better geometry



SNAGGING WHEELS

ADVANTAGES OF CUMI WHEELS



- 1. Excellent cutting action
- 2. Higher productivity
- 3. Controlled wear and longer wheel life
- 4. Burn free surface
- 5. Unparalleled safety

SHAPES

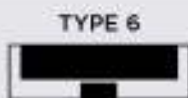
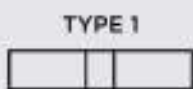

PORTABLE SNAGGING WHEEL

WIDTH OF PRODUCT RANGE

Abrasive Used	CUMI Code	Grit	Diameter		Thickness		Speed mps	Hardness	Structure
			mm	inch	mm	inch			
Zirconia Alumina	AZA	12 - 24	50 - 200	2 - 8	10 - 25	1/64 - 1	50	M - R	2 - 9
Silicon Carbide & Brown Aluminium Oxide blend	CA								
Black Silicon Carbide	C								
Brown Aluminium Oxide	A								

Material	For Better Life	For Better MRR
Carbon Steel & Low Alloy Steel	A163 R3 B1215	A163 R5 BM4
High Alloy Steel & Stainless Steel	A163 R2 BM4	A163 Q5 BM4
Hi-Chrome Steel	AZA163 TDR1175	AZA143 B1214
Grey Cast Iron & SG Iron	C163 Q3 B1551	CA163 TDR1219

PEDESTAL & SWING FRAME SNAGGING WHEEL

WIDTH OF PRODUCT RANGE

Abrasive Used	CUMI Code	Grit	Diameter		Thickness		Speed mps	Hardness	Structure
			mm	inch	mm	inch			
Zirconia Alumina	AZA	12 - 20	300 - 750	12 - 30	25 - 100	1 - 4	50	P - T	2 - B
Silicon Carbide & Brown Aluminium Oxide blend	CA								
Black Silicon Carbide	C								
Brown Aluminium Oxide	A								

Wheel Type	Type	For Better Life	For Better MRR
PEDESTAL	Carbon Steel & Low Alloy Steel	A163 R2 B1215	A163 TDR1220
	High Alloy Steel & Stainless Steel	A163 R2 BM4	A163 R5 BM4
	Hi-Chrome Steel	AZA123 TDR1175	AZA143 B1214
	Grey Cast Iron & SG Iron	CA145 TDR505C	CA163 TDR1219
SWING FRAME	Carbon Steel & Low Alloy Steel	A163 S3 B1215	A163 TDR1220
	High Alloy Steel & Stainless Steel	A143 TD722	A163 TDR1220
	Hi-Chrome Steel	AZA123 TDR1175	AZA143 TDR1214
	Grey Cast Iron & SG Iron	C163 T3 BSG	CA163 TDR1219

BONDED ABRASIVES

CUP WHEEL GRINDING



CUP WHEEL GRINDING



BONDED ABRASIVES

CUP WHEEL GRINDING

ABOUT CUP WHEEL GRINDING

CUMI's Cup wheels are designed for grinding of stone and welded joints of metal by means of portable grinders.

Available in both straight and tapered shapes, CUMI's Cup wheels are available in a wide range of grit sizes from Grit 16 to Grit 220 to meet all grinding / finishing needs.

FEATURES:

- Threaded nut insert for easy mounting
- High strength phenolic resin for better safety
- Unique grinding aids for cooler cutting action
- Advanced manufacturing facility for better control of geometry and wheel vibration
- High performance zirconia grains for heavy duty grinding



CUP WHEEL GRINDING

ADVANTAGES OF CUMI WHEELS



1. Fast cut rate
2. Smooth running
3. Long tool life
4. No vibrations
5. Burn free & smooth finish

SHAPES

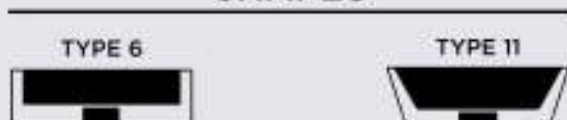

METAL

WIDTH OF PRODUCT RANGE

Abrasive Used	CUMI Code	Grit	Diameter		Thickness		Speed mps	Hardness	Structure
			mm	inch	mm	inch			
Zirconia Alumina	AZA	12 - 24	100 - 200	4 - 8	50 - 100	2 - 4	50	M - R	2 - 9
Silicon Carbide & Brown Aluminium Oxide blend	CA								
Black Silicon Carbide	C								
Brown Aluminium Oxide	A								

Variant	Type	For Better Life	For Better MRR
Portable	Carbon Steel & Low Alloy Steel	A163 R3 B1215	A163 R5 BM4
	High Alloy Steel & Stainless Steel	A163 R2 BM4	A163 Q5 BM4
	Hi-Chrome Steel	AZA163 TDR1175	AZA143 TDR1214
	Grey Cast Iron & SG Iron	C163 Q3 B1551	CA163 TDR1219

STONE

WIDTH OF PRODUCT RANGE

Abrasive Used	CUMI Code	Grit	Diameter		Thickness		Speed mps	Hardness	Structure
			mm	inch	mm	inch			
Black Silicon Carbide	C	24 - 220	100 - 127	4 - 5	38 - 63.5	1-1/2 to 2-1/2	50	J - L	5 - 6

Variant	Type	Recommendation
Portable	Marble	C36 K5 BRT
	Granite	



CUP WHEEL GRINDING



BONDED ABRASIVES

BONDED ABRASIVES TOOL ROOM GRINDING WHEELS



TOOL ROOM GRINDING



BONDED ABRASIVES

TOOL ROOM GRINDING WHEELS

ABOUT TOOL ROOM GRINDING WHEELS

Tool room grinding wheels find vast applications in the manufacture and regrinding of cutting tools like drills, reamers, milling cutters etc.,

CUMI's tool room wheels are available in like plain wheels (type 1), cup wheels (type 6 & 11), dish wheels (type 12), saucer wheels (type 13). They are available in both dry and wet grinding applications

FEATURES:

- Right choice of abrasive grain for specific materials
- Unique bond system for cool grinding and wheel form retention



TOOL ROOM GRINDING WHEELS

ADVANTAGES OF CUMI WHEELS



1. High productivity
2. Excellent form retention
3. Dimensional accuracy
4. Surface finish
5. Burn free component

WIDTH OF PRODUCT RANGE

Abrasive Used	CUMI Code	Grit	Diameter		Thickness		Speed mps	Hardness	Structure
			mm	inch	mm	inch			
Ceramic Aluminium Oxide	CUMISA								
Sharp Crystal Aluminium Oxide	71HA								
Pink Aluminium Oxide	RA	46 - 120	80 - 250	3 1/8 - 9	3 - 25	1/8 - 1	35 & 50	I - L	5 - 7
White Aluminium Oxide	AA								
Green Silicon Carbide	GC								
Silicon Carbide blend	CGC								

SHAPES

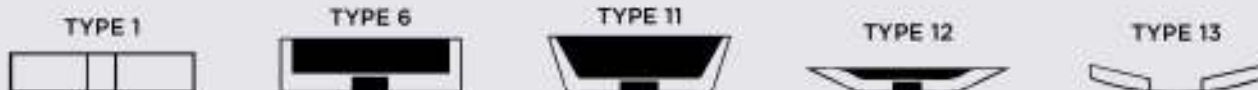

TOOL ROOM GRINDING WHEELS

Material	Operation	Speed	Best	Better	Good
High Speed Steel / Tool Steel / High Alloy Steel	Rough	35	1CUMISA46 J6 VC500	RA46/54 J6 V206	AA46/54 K5 V8
		50	1CUMISA46 J6 VC500 /45	RA46/54 J6 V206/45	AA46/54 K5 V45
	Finish	35	1CUMISA60 J6 VC500	RA60 J6 V206	AA60 K5 V8
		50	1CUMISA60 J6 VC500 /45	RA60 J6 V206/45	AA60 K5 V45
Tungsten Carbide		35	GC60 K5 V52110	GC60 K5 VG	CGC60 K5 VG
		50	GC60 K5 V52110/45	GC60 K5 VG/45	CGC60 K5 VG/45
Special Tool Steels	Rough	35	71HA461 J7 VC500	55A461 J7 VC500	RAA46/54 J6 V206
		50	71HA461 J7 VC500/45	55A461 J7 VC500/45	RAA46/54 J6 V206/45
	Finish	35	71HA60 J7 VC500	55A60 J7 VC500	RAA60 J6 V206
		50	71HA60 J7 VC500/45	55A60 J7 VC500/45	RAA60 J6 V206/45

**HEAD - INTERNATIONAL BUSINESS
VIPIN MALIK**

- ✉ malikvipin@cumi.murugappa.com
- ☎ vipin0810
- ☎ +91 97910 14577
- ☎ +91 44 3000 6194

**SAARC & SE ASIA
KRISHNAMOORTHY**

- ✉ krishnamoorthye@cumi.murugappa.com
- ☎ krishnamoorthy.e
- ☎ +91 98401 88396
- ☎ +91 44 3000 6190
- ☎ +91 44 3000 6191

**RUSSIA
KRISHNA KUMAR**

- ✉ nkrishnakumar@cumi.murugappa.com
- ☎ krishnakumar.naras
- ☎ +91 8754483075

**LATIN AMERICA & AFRICA
VIPIN MALIK**

- ✉ malikvipin@cumi.murugappa.com
- ☎ vipin0810
- ☎ +91 97910 14577
- ☎ +91 44 3000 6194

**EUROPE & KOREA
NEELAKANDAN**

- ✉ neelakandanv@cumi.murugappa.com
- ☎ neels.v
- ☎ +91 814 850 6335

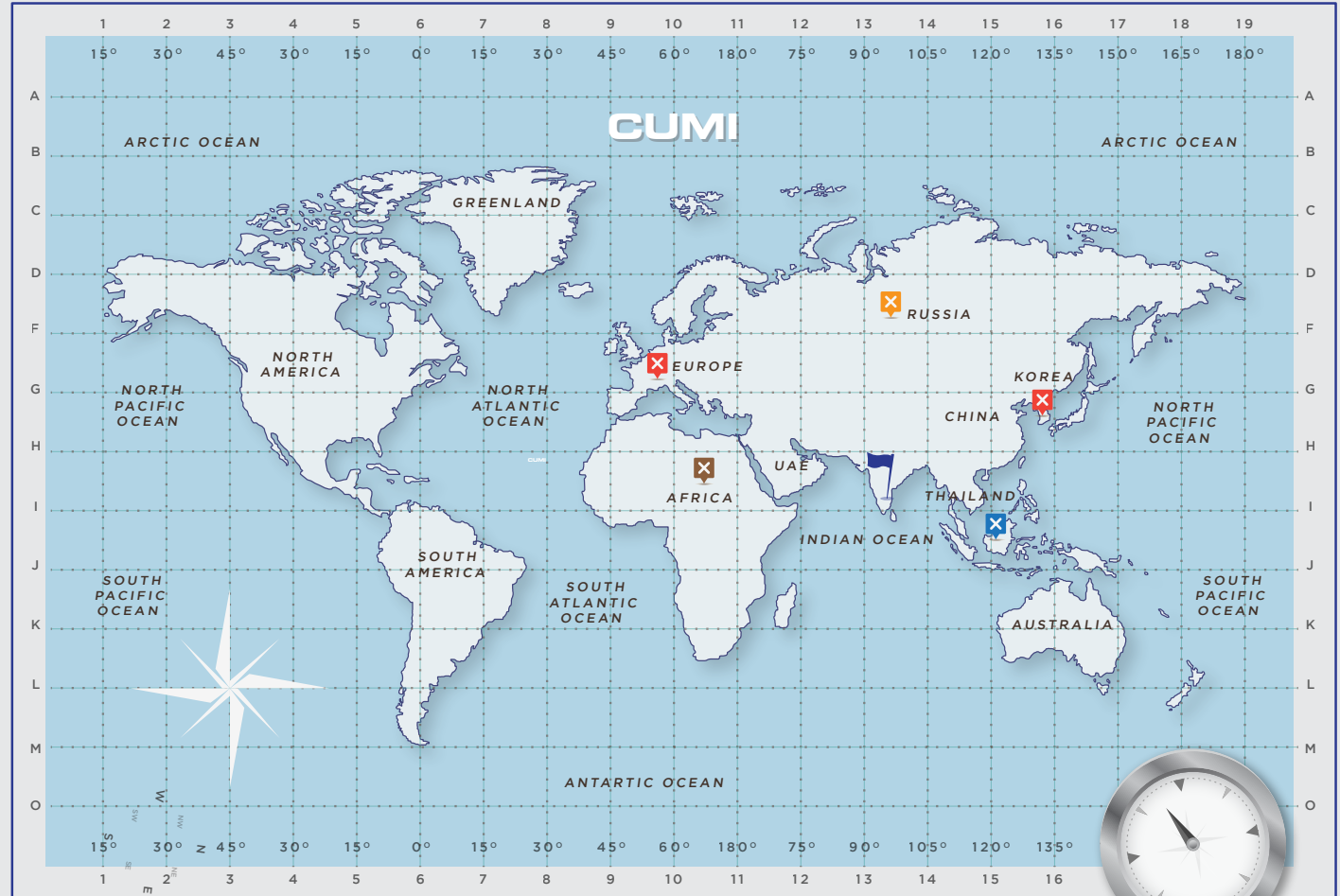

- EASTERN EUROPE
AKSHAY KASHINATH**
- ✉ akshayk@cumi.murugappa.com
 - ☎ +91 814 850 6335

USA

CUMI America Inc.

1119 AVIATION BLVD, HEBRON, KY 41048, US

+1 844 CUMI USA (+1 844 286 4872)

+1 859 372 6606

+1 859 372 6607

nbichkar@cumiusa.com, rsmith@cumiusa.com

MIDDLE EAST

CUMI Middle East Fze, 315, Business Center 3,

P.O. Box 16190, Rak Free Trade Zone, UAE

+971-7-2046181

+971-562226190 / +91-9874686688

+971-7-2046182

sumonroy@cumi.murugappa.com

THAILAND

Wendt Grinding Technologies Ltd.,

109/21, Moo4, Tambol Plukdaeng

Ampur Plunkdaeng, Rayang- 21140, Thailand

+66(0) 38955490 (Dir) 955491/2

+66-86-3075809 (Office Number)

+66(0) 38955493

praveen@wendt-thai.com

AUSTRALIA

CUMI (Australia) Pty Ltd,

29 Gipps Street PO Box 142

Carrington, NSW, Australia, 2294

+61 (02) 49400035

+61 (02) 49400037

usk@cumi.com.au

CHINA

CUMI ABRASIVES AND CERAMICS CO., LTD

No.9, Donghuan Road,

Yanjiao Development Zone, Sanhe City,

Hebei Province, P.R. China, 065201

+86 316 18630663335

darrylwu@cumi.murugappa.com



AUSTRALIA

CUMI (Australia) Pty Ltd,

29 Gipps Street PO Box 142

Carrington, NSW, Australia, 2294

+61 (02) 49400035

+61 (02) 49400037

usk@cumi.com.au

CHINA

CUMI ABRASIVES AND CERAMICS CO., LTD

No.9, Donghuan Road,

Yanjiao Development Zone, Sanhe City,

Hebei Province, P.R. China, 065201

+86 316 18630663335

darrylwu@cumi.murugappa.com



CARBORUNDUM UNIVERSAL LIMITED

Parry House, No.43, Moore Street, 3rd Floor,
Chennai 600 001, India

Tel: +91 44 3000 6194 (Direct)

Fax: +91 44 3000 6191

www.cumiabrasives.com